

DESIGNING ANTENNA SYSTEMS WITH CORPS (COHERENTLY RADIATING PERIODIC STRUCTURES)

D. Betancourt, R. García, A. Ibañez and C. del Río

*Antenna Group, Universidad Pública de Navarra
Campus Arrosadía s/n, 31006 Pamplona
Phone: +34 948169326, Fax: +34948169720
Email: carlos@unavarra.es*

ABSTRACT

In this paper a new philosophy to design antenna systems is presented. It is based on the recently proposed Coherently Radiating Periodic Structures (CORPS). These structures are essentially a periodic structure which all the elements are radiating elements coupled coherently (in-phase).

This principle could allow the designer to simplify the needed feeding network for many array antenna systems since some elements could be coupled from the neighbouring ones, keeping the original excitation profile.

It will be also shown in this paper how the three dimensional version of CORPS could be understood as a focusing planar lens, since it is possible to distribute the information of one element to many radiating elements by using the coherent coupling mechanism between all the elements of the whole structure. With this configuration, many directive beams could be really close to each other, increasing the possibilities to handle high resolution in imaging systems.

1. INTRODUCTION

One of the most important requirements of all the antenna systems is the angular resolution achievable, to be able to distinguish two punctual sources placed quite close to each other in far field. The angular resolution is determined by the possibility of having high directive beams quite close to each other.

With the actual technologies, the antenna systems having one or more high directive beams at microwave and millimetre wave ranges could be classified in two kinds of systems:

- a).- systems with a *unique lens* or focusing device, and
- b).- systems with *multiple lenses*.

In the first case, the possibility to increase the number of beams passes by admitting some kind of distortion of the beams placed out of focus. Practically all the more commonly used antenna systems are included here, some of them with more focusing capabilities in

the lens or focusing device and some others with more directive radiating elements. The classical parabolic reflector antenna with the low directive feeder could be an excellent example of this type of systems, but also the multi-feed reflector antenna configuration. The HFI and LFI experiments of PLANCK [1] use this configuration of multiple feeds and multiple frequencies illuminating only a unique reflector system.

The second case is the case of the big arrays configurations, where the radiating elements are complete antenna systems disposed over a large area with a special lattice. Examples as ALMA [2], VLA [3], etc, are well known by all the scientific community.

As it is very well known, in both cases, the main problem is the angular resolution achievable, since there is no possible to reduce the distance between high directive beams below the aperture dimensions of the radiating elements.

The limitation of having a small number of detectors per lens reduces the possibilities of natural extension of the actual technology to handle a large number of detectors. In front of that limit, the only valid solution, to enlarge the system, is to iterate the full system itself, obtaining some kind of compound eye of some insects, where there are a lot of small antennas (detectors) focused by its own lens (*ommatidia*), conform a complete visual system.

In this sense, the array configurations of radiating elements, apparently without any lens, like ENVISAT-ASAR [4], could be included here as being a combination of multiple different antennas with certain directivity.

Of course, all these systems, because of the non-negligible distance between detectors, will always have a limited resolution.

Nevertheless, in the nature there are some examples of antenna systems with impressively high resolution. One of the most extended is the human eye that it is working at optical frequency range and the achievable resolution is really impressive. Let's study a little bit

more in detail the working principle of the human eye to see if this could help us to understand the way to define such high resolution systems.

1.1. Resolution of the human eye

The human eyes have an impressive performance. They are able to focus near and far objects automatically; they have possibilities to see under bad circumstances (low light); they are able to control de entrance of light to prevent possible saturation of photoreceptors; and finally, the most impressive feature, the really high resolution of the obtained images.

But, it is even more impressive if we try to understand the human eye under antenna parameters. To be able to distinguish two points quite close to each other at certain distance, we should need some kind of really high directivity. In some experiments performed by the authors of this paper, the needed directivities were close to 90dB, which means, that the main beam is subtended under angles of less that 1 minute of arc. But this is even more amazing if we think that many other beams should be simultaneously placed every 1 minute of arc, to be able to distinguish the changes of light intensity and colour.

Some people like to assign to the brain the capabilities to obtain such high resolution images, but it is clear that it could be difficult to “generate” small details that have never been received by the eye. It could be understandable some kind of interpolating post-processing technique to try to solve points placed between photoreceptors to obtain a continuity sensation of the images, but this never would generate additional details in the image increasing the resolution.

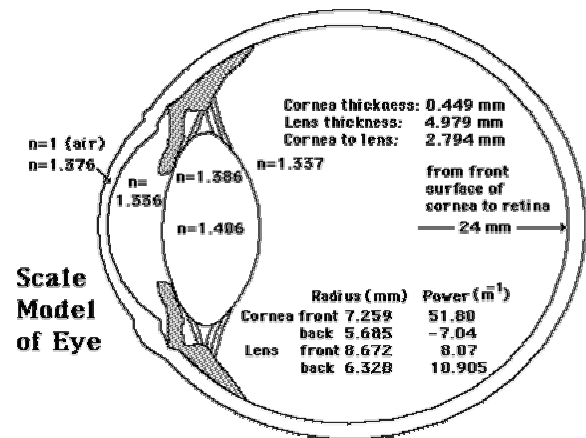

Fig. 1.- Scale model of the human eye, including the different lenses and their refractive indices.

Thus, it is clear that some more investigation about the human eye could be very interesting to try to clarify these aspects that seems be not so clear.

First of all, we will collect some data from the human eye in order to illustrate the working principle of the human vision, and to evaluate the causes of the high resolution.

In principle, in the human eye, the light passes through the cornea and the crystalline having a focus situated just over the retina. The total refractive power of the human eye is measured in dioptres and it is determined by the inverse of the focal length, being 62 the considered normal value for a current human eye [5]. This means that the focal length is then 16 mm, and it corresponds with the separation between the crystalline and the retina. Then, the images in front of the eyes (just at the focal plane outside the eye) will be inversely projected over the retina as in a photographic camera.

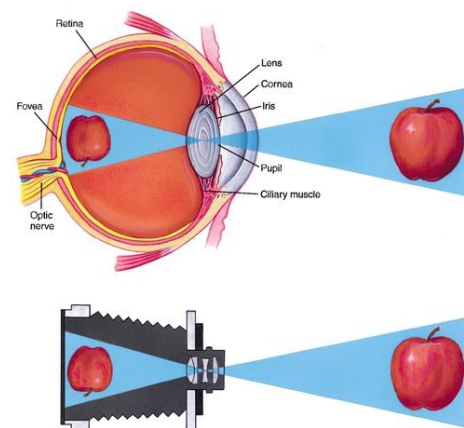

Fig. 2.- Optical focusing system of the human eye and a photographic camera, showing the similarities in the inverted projected image over the retina or the film respectively.

Over the retina there are special cells, photoreceptors, specially prepared to receive the information modulated at optical frequencies introducing this information in the neural system to the brain to process. There are different kinds of photoreceptors: cones and rods. The cones responsible of the coloured vision and the rods more related with the vision under poor lighting conditions.

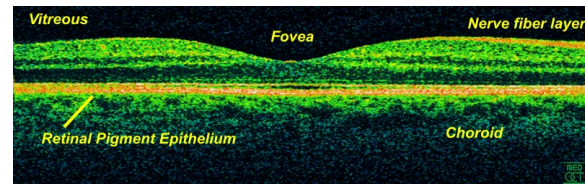

Fig. 3.- Optical Coherence Tomography at 800nm of the Macula in a human retina.

It is also well known that we really have properly focused a small cone subtended in an angle of less than one degree, and the responsible of this is a small area on the retina just centred at the vision axis called

Macula recognized as a depression of the retina surface being the deeper point known as *Fovea*.

In the Macula, the density of cones is 160.000 per square millimetre being the main responsible of the focused central vision. The Macula is in fact acting like a divergence lens, dispersing the parallel rays arriving close to the optical axis over a wider area of receptors. This divergence effect is not included properly in the optical system of the eye since the Fovea is only $100\mu\text{m}$ deep, and the dispersion effect is really small and only relevant for the increase of area of receptors affected.

It is also known that the cones diameter is approximately $1.5\mu\text{m}$ and the separation between two cones is about $0.5\mu\text{m}$.

With these dimensions, if we apply the photography principle and we expect to obtain focused over the retina the inverted image, we could calculate the resolution of the retina image simply translating the separation between two cones outside the eye. To solve two different points outside, the retinal image should have an “unexcited” cone between two other excited ones by the two points respectively, given a distance of $4\mu\text{m}$ as the minimum distance necessary to solve two points on the retina. Translating this distance out of the eye up to a distance of 350mm (reading distance), these resolution step is $84\mu\text{m}$.

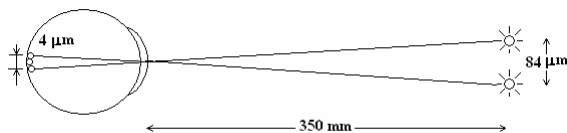

Fig. 4.- First approximation of human eye resolution.

This could mean that we shouldn't be able to distinguish anything smaller than this resolution step, but really we are able to see below that limit, so something more should be considered.

1.2. Higher resolution explanation

Some authors suggest that there is a very quick and small oscillation movement of the eyes that could help to refill the empty spaces between cones.

At that point of the explanation it is important to think a little bit about the detection mechanism. The cones are not detecting the carrier signal (optical frequencies); they are really detecting the modulated signal. Certainly, each type of cone has its own frequency response to optical frequencies, being more sensible to different colours: red, green and blue.

In a simplified model, we could think that the cones could be acting as integrators, just counting the number of photons received.

Under the assumption of the rapid and small vibration of the eye to increase the resolution, it could be argued that it could really be difficult to think that the brain could know exactly the position of the eye when each photon arrives to each cone to reconstruct the higher resolution image. Assuming this integration behaviour, this vibrating phenomenon could really diffuse the image over the retina.

Furthermore, in the optical theory the light is considered to travel in straight lines, but really some diffraction should be considered since the light is also a wave. This means that really the light will not focus in a single point but in an area. This phenomenon again generates some diffusion of the retina image.

But even more, if we study the chemistry reactions of the reception mechanism of a photon by a cone, some horizontal coupling between neighbouring cones have been reported [5], in some kind of amplifying effect ensuring that all photons are properly received by the retina.

All these three phenomena generate some kind of distortion in the retina image since the information of one photon is effectively spread over some area of the retina, either by the diffraction of light, by the movement of the eye or by the chemistry mechanisms.

So in summary, originally where we were expecting to obtain an image perfectly focused over the retina, since is placed just at the focal plane of the eye lenses (cornea and crystalline), and we are really obtaining a totally de-focused image.

Originally, we start this study to explain the higher resolution of the human eye. Could all this really explain the higher resolution? Or, on the contrary we should continue investigating other causes to justify the higher resolution.

Let's follow a little bit more inside the composition of the retina. Looking carefully at the total composition of the retina, we found two additional layers of neurons over the light receptors highly interconnected. These two layers could perform some kind of image processing trying to build a higher resolution image to be sent to the brain through the optical nerve.

This could be possible thanks to the inherent coherence of the eye as a detector of photons. The effect of a photon over the retina finally excites a set of photoreceptor cells, as it was justified above. With the neural networks we could identify without any problem

the impact point calculating the position of the maximum.

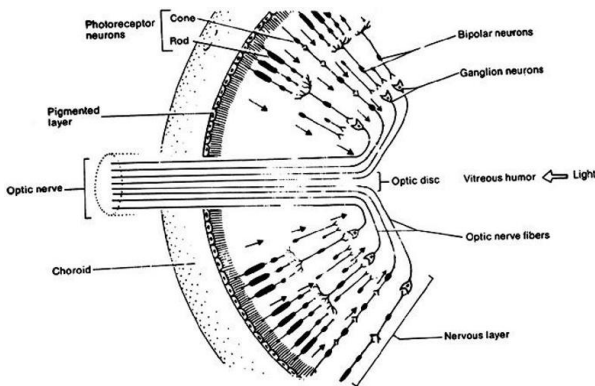

Fig. 5.- Detailed disposition of the neurons and the photoreceptors inside the retina of a human eye.

To do this in only one layer, we should have as much neurons as detecting cells over the retina, being every neurone connected to several retina cells (this number should corresponds with the number of excited cells by a single photon) and applying a threshold function.

Under the inherent coherence conditions of the detection mechanism, the linearity perfectly applies with any distortion phenomena, so by using a single layer of neurons we really could clarify the diffused retinal image, effectively increasing the resolution of the received image.

There are some advantages of having a diffuse image over the retina to be clarified afterwards, but the most important is the robustness of the vision system is substantially improved since the information over the retina is redundant. By this method, it could be understandable that different types of cones and rods could be working together to define the small details of the image in front the eyes.

Coming back to the antenna design theory, it is clear that to obtain a high directive beam, some area over the retina should be effectively used, having highly overlapped radiating areas that could justify very close high directive beams, and therefore, high resolution.

2. DEFINITION OF COHERENTLY RADIATING PERIODIC STRUCTURES

In the range of microwaves and millimetre waves, the detecting mechanism of the antenna systems are not naturally coherence like the human eye is, and some additional care should be taking into account to apply the same principle to that lower frequencies.

The CORPS (Coherently Radiating Periodic Structures) will be the kind of antenna systems that

uses this mechanism to obtain high resolution at microwave and millimetre wave frequency ranges.

The CORPS are essentially a periodic structure which all the elements, equally shaped and sized, are radiating coherently, and they consists basically on the use in our favour of the mutual coupling always present in most of the antenna arrays.

The key idea is to accept the inevitable presence of the mutual coupling between elements but force it to be coherent (in-phase), as it was naturally in the human eye, controlling the coupling mechanism.

For instance, working with patches over thick substrate as array elements, the coupling could be adjusted to be in-phase (coherently coupled) by separating them an effective wavelength of the substrate wave-mode.

At the same time, by doing this adjustment to have the mutual coupling in phase, the periodic structure formed by the elements is tuned at the second rejecting band of the filter, since the lattice is a full wavelength, so no propagation is allowed horizontally through the substrate. Then, only the elements surrounding the active one (fed) will couple some power by reactive coupling (Fig. 6).

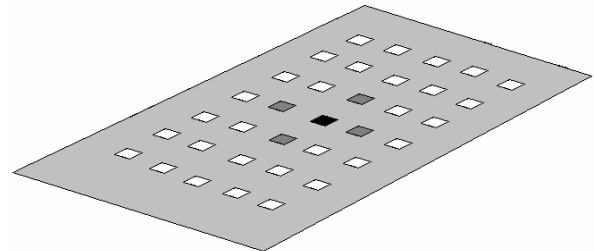

Fig. 6.- Coupled elements (gray) when the central element (black) is being fed.

All this could be understood as we have effectively defined a horizontal controlled coupling, that could be smartly used to simplify the last part of the feeding network, simplifying the waveguide network to drive the excitations of all the elements of an array; some elements are directly excited by the network and some others excited by the horizontal coupling from the previous ones (Fig. 7).

3. POSSIBILITIES OF CORPS

Despite the concept of CORPS could be quite clear and understandable, and having a visual human system that could be working under the same principles, there are many fields included in CORPS that will need further developments.

One of these fields is clearly the mutual coupling, since up to now the main goal in array designing procedure was to avoid the presence of that coupling and now is taking a key role in the desired behaviour of the global antenna system. Probably, it could be interested to recuperate some discarded radiating elements or configurations by their high mutual coupling, since now, if it is possible to control the coupling, could be the most appropriate configuration to be used in CORPS.

For instance, the thick substrates for patch antennas are usually discarded, despite the improvement of bandwidth, because of the possibility to excite substrate wave modes; and now they could be used as a very effective coupling mechanism to spread coherently the information through the CORPS structure.

Nevertheless, under the ideal hypothesis of having the coupling under control, some really interesting applications could be possible.

Thus, the concept of CORPS could be applied just translating the vision system of the human eye, to define a high resolution camera. The coherently radiating periodic structure, CORPS, will ensure the coherent diffusion of the received image. The needed post-processing to obtain the high resolution image is as simple as the one proposed for the human eye, i.e., applying a simple mask to focus again the image.

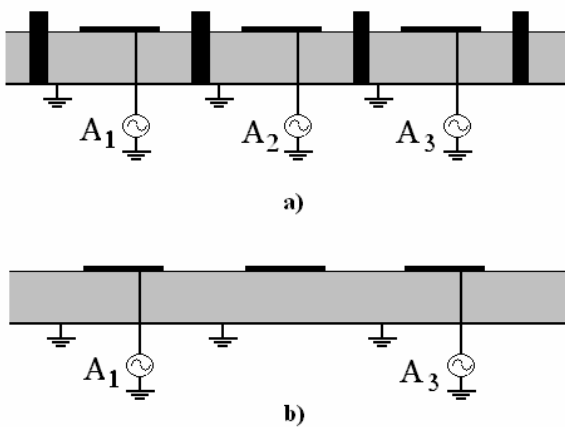

Fig. 7.- Array of three elements isolated with the corresponding excitations (a), and the equivalent array of a CORPS, coupled radiating elements, where only two excitations are required, since the central element will be excited horizontally by the two neighbouring elements (b).

In transmission, working with a set of orthogonal modulated sources, we could take profit of the diffusion characteristic of these structures, assuming that every input sample will be radiated by several elements at the other side of the structure, defining

high directive beams very close to each other (Fig. 8 and 9), highly overlapped.

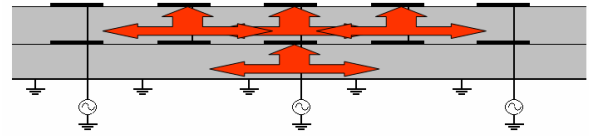

Fig. 8.- Expansion of the central excitation through the CORPS, spreading the information introduced to that element and being effectively radiated by a set of elements of the radiating layer of the structure.

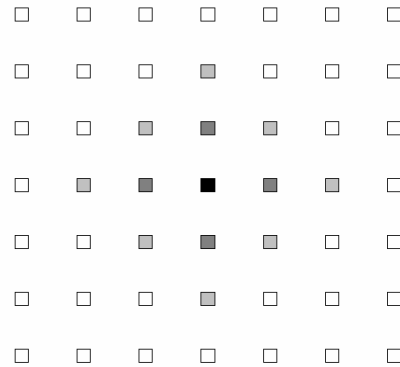

Fig. 9.- Top view of the coupled elements of the CORPS shown in Fig. 8. The grey intensity shown the coupled power profile obtained at the upper layer.

Also in transmission it could be also oriented to reduce the number of samples at the input port since the empty spaces between inputs samples will be refilled by the horizontal coherent coupling, reducing the complexity of the feeding networks of many array antenna systems (Fig. 7).

4. EXAMPLES

4.1. Using CORPS as superstrate

A very simple application of CORPS that could help the reader to understand the possibilities of these structures is to use a slab of CORPS as superstrate of an existing antenna system. In particular, the structure is a pile of layers of resonating patches, slots and patches again, all of them distributed in a square lattice [6].

The first example of CORPS of this paper is based on a 4.5 dielectric, very similar to the one presented in [6] combining patches and slots in three layers. The working frequency is selected to be 9.2 GHz and the lattice 12 mm.; the square patch edge is 5.5 mm and the crossed-slot has a width of 0.8 and a arm length of 4.8mm. The patches and slots are approximately resonating at the working frequency and the lattice is

tuned to have a coherent coupling between the elements.

Illuminating the CORPS with a simple patch, all the resonating patches of the first layer of the CORPS are acting as active elements (fed elements) of the phased array, taking a sample of the incident field at their locations.

Since, the patches and the slot are tuned to be resonant at the working frequency, a vertical pass-band behaviour could be expected.

Under these conditions the Huygens principle perfectly applies and the original field generated by the exciting patch should be reproduced at the other side of the superstrate, since the distance between radiating elements is smaller than a free-space wavelength.

However, the far field pattern including the CORPS as superstrate (dashed blue line, Fig. 10) shows a significantly higher directivity than the case of having the patch isolated (full red line, Fig. 10).

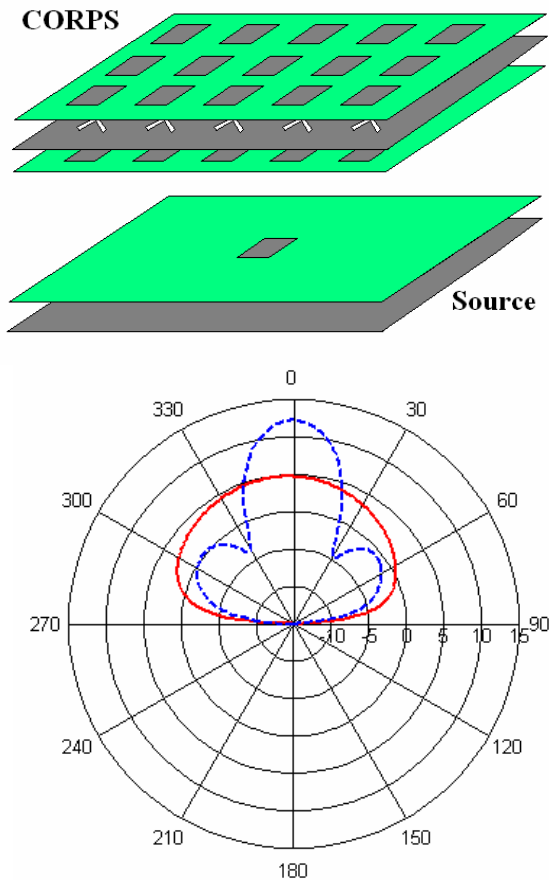

Fig. 10.- Far field pattern comparison of the isolated exciting patch (continuous) and the configuration including the CORPS as superstrate (dashed).

Furthermore, if we use an antenna array of three patches separated more than a wavelength in the free

space to illuminate the superstrate, we could verify the same behaviour.

Now, the new source is under-sampling the uniform current distribution and therefore grating lobes will appear in our far field pattern. By placing the CORPS superstrate, the grating lobes are strongly reduced and the gain increased.

This phenomenon cannot be explained by the Huygens principle, since the source should be reproduced exactly if the distance between elements is smaller than a free-space wavelength, exactly our case, and nevertheless, the far field pattern is substantially changed.

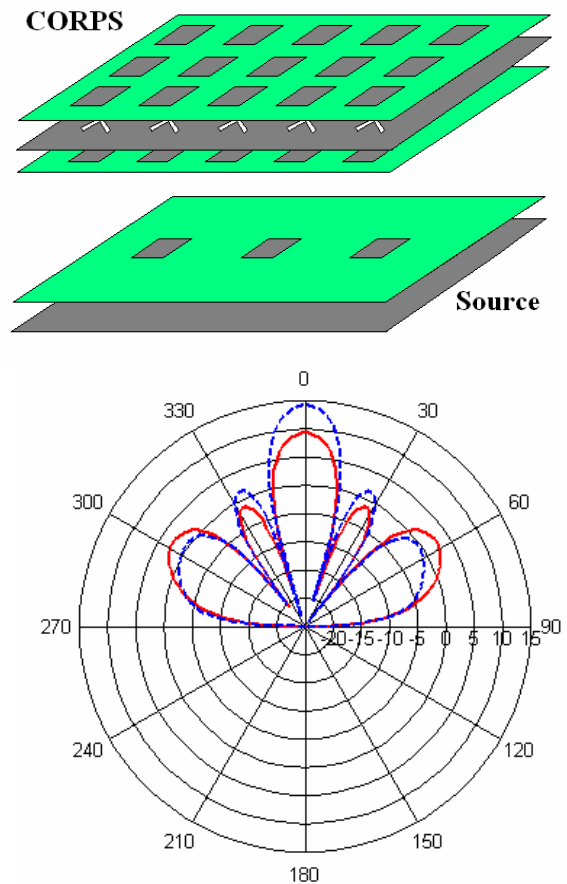

Fig. 11.- Far field pattern comparison of the isolated exciting patch array (continuous) and the configuration including the CORPS as superstrate (dashed).

The explanation for this behaviour is quite simple, the elements of the first layer of the CORPS couple power not only upwards but horizontally to their neighbours, so the “samples” of the incident field are being distributed inside the CORPS. In some sense, this could be understood as each “sample” of the incident field is effectively being radiated coherently by a set of elements of the last layer of the CORPS. Of course, the effective radiating areas are strongly overlapped, and this is directly related to a real improvement of the

angular resolution between the first (directly sampled incident field) and last layer (reconstructed field) of the CORPS superstrate.

4.2. CORPS applied to array antennas

In this case, we will apply the CORPS to a longitudinal patch antenna array configuration, in order to show the real possibilities to simplify the feeding networks of more complicated array configurations.

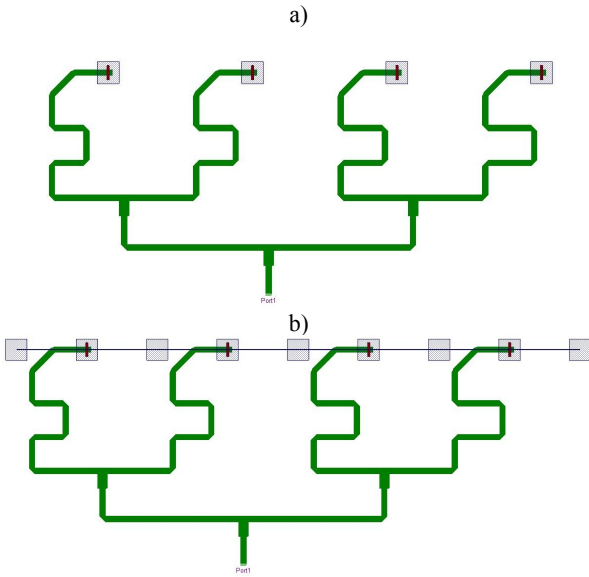

Fig. 12.- (a) Linear array of square patches coupled with ground plane slot with uniform amplitude and phase shift of 45 degrees; (b) the previous array including additional patches forming a CORPS.

The initial configuration is a linear array of four square patches, on a 4.5 permittivity dielectric, separated a distance of 1.256 free-space wavelengths, and fed by a microstrip lines via a slot in the ground plane with a phase shift of 90 degrees.

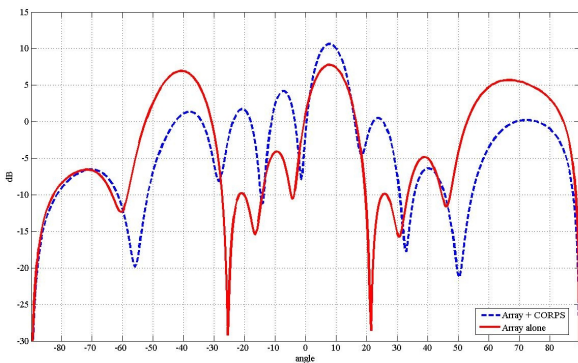

Fig. 13.- Far field pattern comparison between the array alone (continuous line) and the new CORPS configuration (dashed line).

The alternative design introducing the CORPS concept is applied introducing in between the original patches additional ones, identically shaped, sized and tuned at the same frequency. In order to increase the coupling between all the patches, a thin wire (0.1 mm) interconnects all the patches at the radiating layer. This could be another possibility to enhance the mutual coupling between elements if the substrate is not allowing the substrate modes and we need stronger couplings.

The far field pattern is presented in Fig. 13, where the phase shift of about 10 degree could be observed, as well as the strong grating lobes around -40 and +60 degrees.

As in the previous case, some improvement of the directivity is observed as well as an effectively decrease in the grating lobes.

This could be explained very intuitively just by looking at the resulting formula for the radiated electric field of a linear array.

$$\vec{E}_{rad}(\vec{r}, t) = \vec{E}_0(\vec{r}, t) \cdot AF(\Psi) \quad (1)$$

being \vec{E}_0 the field radiated by an isolated element, $AF(\Psi)$ the array factor and Ψ the electric angle function of the particular disposition of the array elements.

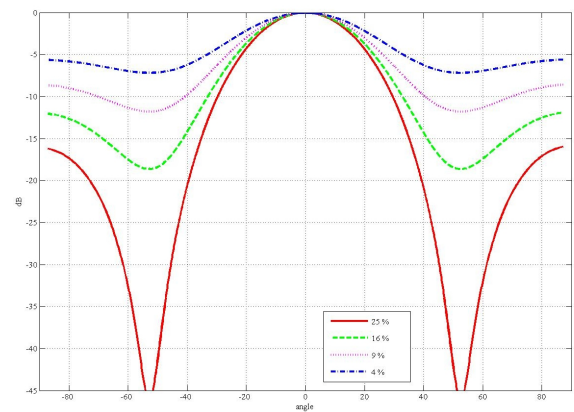

Fig. 14.- Array factor of three elements with a triangular amplitude distribution and uniform phase, for different coupling levels.

The radiation of the whole structure could be calculated just modifying \vec{E}_0 , since the radiating element has been changed and now includes other patches around radiating coherently (in phase). In Fig. 4 is represented the factor to apply to the far field pattern of the radiating element. It could be seen that because of the distance between elements now is the half we had between the original patches, now, instead of grating

lobes just 50 degrees from bore-sight, we have nulls or some kind of minimum of the radiation pattern.

Ideally, the optimum coupling will be exactly in phase and coupling 25% of the power to each of the two neighbour elements (continuous line of Fig. 14). In this case, the reduction of the grating lobes will be maximized.

4.3. CORPS applied to Multi-beam antennas

In the same way that the human eye works with many beams simultaneously, the CORPS antennas could also manage different and orthogonally beams at the same time.

Assuming the effective diffusion of the information as the power passes through the CORPS, including sufficient number of layers to define the desired directivity, we could generate a beam in a particular direction just with only three elements of the first layer of the CORPS.

We only need three points to define a plane, in our case a phase front, so with only three input ports, we could have totally defined the direction of propagation of one beam.

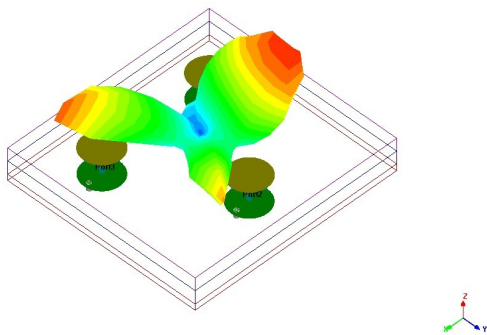

Fig. 15.- Radiated field of three circular patches placed on the three vertices of a equilateral triangle.

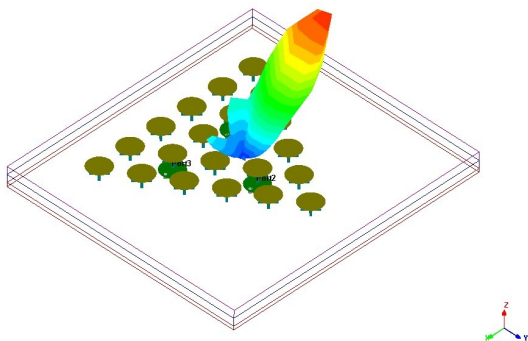

Fig. 16.- Radiated field of the same three elements of Fig.15 embedded in a triangular CORPS of lattice half the distance between original circular patches.

In Fig. 15, the radiation of three elements in a triangular lattice is shown. In principle the lattice is bigger than a wavelength so grating lobes appears.

Just embedding these three elements in a CORPS of crossed slots and an additional layer of circular patches, the new radiation pattern will be improved in directivity and grating lobes, as it is shown in Fig. 16.

Applying linearity, if other three elements are used to create a new beam in a different direction, it would be any problem to have both beams being simultaneously radiated by the structure

5. CONCLUSIONS

In this paper, the new concept of the CORPS has been presented. It is inspired in the human eye model and opens many opportunities to enhance the resolution in many antenna systems.

The idea of CORPS could be also applied to reduce the complexity of feeding network of many array antenna configurations, and to use a big number of high directivity orthogonal beams, approximately radiating from the same effective area.

Some further development in the characterization of the mutual coupling, the selection of the radiating elements, best topologies, etc. should still be performed in the future.

REFERENCES

1. <http://www.esa.int/science/planck>
2. <http://www.alma.nrao.edu/>
3. <http://www.nrao.edu/>
4. <http://envisat.esa.int/instruments/tour-index/asar/>
5. Kaufman, P.L. and Alm, A., "Adler's Physiology of the eye", Edited by P. Kaufman, Mosby, tenth edition, ISBN 0-323-01136-5.
6. D. Betancourt, A. Ibáñez, R. García and C. del Río, "Meta-material behaviour of the new Coherently Radiating Periodic Structures (CORPS)", Int. Workshop on Methamaterials LATSIS 2005, Laussane, Switzerland, February 2005.