

E.T.S. de Ingeniería Industrial,  
Informática y de Telecomunicación

**Comparative Analysis of Freight Transportation Environmental  
Impact Considering Alternative Road Routes in Navarre**



Máster Universitario en  
Ingeniería Industrial

Trabajo Fin de Máster

Autor: Xabier Mendaza Sagastizabal

Tutores: Javier Faulín y Adrián Serrano

Pamplona, 25/11/2020



# INDEX:

0. MOTIVATION .....	8
1. INTRODUCTION .....	9
1.1. Sustainable Transportation.....	9
1.1.1. Economic Vision of Sustainable Transportation.....	10
1.2. Road freight transport .....	12
1.2.1. Characteristics of road Freight Transportation .....	13
1.2.2. Types of vehicles.....	14
1.2.3. History of road freight transportation.....	15
1.2.4. Situation of road freight transportation.....	17
1.2.5. Cost calculation of freight transportation .....	19
1.2.6. Negative Externalities Affecting Road Transportation .....	20
1.2.6.1. Air pollution .....	20
1.2.6.2. Greenhouse gases .....	21
1.2.7. Administrative features of road freight transportation .....	23
1.2.8. Fuel Efficiency in trucks .....	28
1.2.9. Regulations for emissions of trucks.....	31
1.3. Intermodality of transportation.....	33
2. ROAD TRANSPORTATION IN WESTERN PYRENEES: N121A VS A15 .....	35
2.1. Definition of the problem .....	35
2.2. Roads Compared in this Project.....	36
2.2.1. A-15 Highway.....	36
2.2.2. N-121-A National Road .....	37
2.2.3. Accident rates in N-121-A and 2+1 conversion .....	38
2.2.4. Viability analysis of proposal for improvement of N-121-A into a 2+1 road	40
2.2.5. Internal Rate of Return Calculation .....	44
2.3. Transportation at the Pyrenees .....	46
2.4. Routes definition.....	50
2.4.1. Geographic Information System.....	50
2.5. Effect of gradients in roads .....	54
2.5.1. Passenger cars .....	54
2.5.2. Road freight vehicles .....	54

3.	ECONOMIC COSTS .....	56
3.1.	Private operating costs .....	56
3.1.1.	Calculation of private operating costs.....	56
3.2.	External costs.....	58
3.2.1.	Average and marginal external costs .....	59
3.2.2.	Calculation of external costs .....	60
4.	MODELLING OF THE PROBLEM .....	63
4.1.	Modelling of the routes .....	63
4.1.1.	Calculation of Gradient and Speed Profiles of Roads.....	64
4.2.	Modelling of the vehicle .....	67
4.2.1.	Tractor unit .....	67
4.2.2.	Semi-trailer .....	68
4.3.	Modelling of emission calculation (Applied models).....	69
4.3.1.	MODEL 1: Instantaneous Fuel Consumption Model .....	69
4.3.2.	MODEL 2: Methodology for Calculating Transportation Emissions and Energy Consumption (MEET).....	70
4.3.3.	MODEL 3: Comprehensive modal emission model .....	74
4.3.4.	Assumptions for the models.....	76
5.	RESULTS .....	81
5.1.	Results for model 1 .....	81
5.2.	Results for model 2 .....	81
5.3.	Results for model 3 .....	83
5.4.	Sensitivity analysis .....	84
5.4.1.	Change in the shape of the vehicle (Drag coefficient) .....	84
5.4.2.	Using an unloaded vehicle (tractor and empty semitrailer) .....	85
5.4.3.	Using a single tractor unit.....	86
5.4.4.	Change in the vehicle (using a smaller vehicle).....	87
6.	CONCLUSIONS .....	91
7.	BIBLIOGRAPHY .....	94
8.	ANNEX.....	99
8.1.	Acoustic study .....	99
8.1.1.	Representative vehicles.....	100
8.1.2.	Accoustic equivalence E and grade correction.....	100
8.1.3.	Speed .....	100

8.1.4.	Application of the method to N-121-A and A-15 (AP-15) .....	101
8.1.5.	Results.....	102
8.2.	Study of biodiversity and protected areas.....	103
8.2.1.	Protected areas close to N-121-A and A-15 .....	105
8.2.2.	Protected areas close to N-121-A.....	105
8.2.3.	Protected areas close to A-15: .....	108

# ILLUSTRATION INDEX

## Figures:

Figure 1:Sustainable Transportation .....	9
Figure 2: Costs and benefits of freight transportation.....	11
Figure 3: Road freight transportation.....	13
Figure 4: Karl Benz (1844-1929) .....	15
Figure 5: One of the first internal combustion trucks by Daimler in 1896 .....	16
Figure 6: Air Pollution .....	20
Figure 7:Greenhouse Effect (Retrieved from climatecentral.org) .....	21
Figure 9: Water pollution .....	22
Figure 10:Traffic congestion .....	22
Figure 11: Traffic accidents.....	22
Figure 12: Example of a waybill.....	24
Figure 13: Kinds of dangerous loads.....	25
Figure 14: Transportation card MLD .....	26
Figure 15: Evolution of EU truck engine power since the 1990s. (Source: transportenvironment.org) .....	29
Figure 16: Comparison of EU and US fuel tractor trailer consumption(Source: transportenvironment.org) .....	30
Figure 17:Different intermodal estructures .....	34
Figure 18: A-15 highway .....	36
Figure 19: N-1 highway.....	37
Figure 20:AP-8 highway.....	37
Figure 21: N121-A National Road .....	37
Figure 22: 2+1 road.....	39
Figure 23: Improved intersection in T .....	40
Figure 24: Accident in N-121-A of January 2020 in which two young boys of 19 and 21 years old died .....	41
Figure 25: Types of costs of accidents.....	42
Figure 26: Calculation of IRR with Gabilos software calculator tool.....	45
Figure 27: Traffic flows of different modes from Iberian peninsula to Europe (Source: Observatorio hispano-francés de Tráfico en los Pirineos, 2019) (Translated from Spanish) .....	46
Figure 28:Number of heavy vehicles in roads N121-A and A15 in Navarre-Gipuzkoa border (Source Plan de Aforos Gobierno de Navarra 2018) .....	48
Figure 29: Number of heavy vehicles per day in main Pyrenean roads (Source: Observatorio hispano-francés de Tráfico en los Pirineos, 2018) (Translated from Spanish) .....	49
Figure 30: Example of simplification of data because of use of a GIS 2.....	50
Figure 31: SITNA Geoportal .....	52
Figure 32: Kilometric points of the road from ArcGIS software.....	52

Figure 33: Decelerations of heavy trucks in gradients (Source: Aashto, Translated from Spanish) .....	55
Figure 34: ACOTRAM transportation cost calculator .....	56
Figure 35: Parameters introduced in ACOTRAM.....	57
Figure 36: Results got with ACOTRAM .....	58
Figure 37: Well-to-tank (WTT) emissions (Source: EU Science Hub, European Commission) .....	60
Figure 38: First division of both N-121-A and A-15 roads .....	63
Figure 39: Different segments in which both roads were divided according to the speed of the trucks.....	64
Figure 40: Examples of elevation profiles got from N121-A using Google Earth, from the beginning of the route in (kilometric point .,85) to Belate tunnel.....	65
Figure 41: View of N-121-Awith Google Street Vie .....	66
Figure 42: DAF XF 430 FTT 6x4 Tractor.....	67
Figure 43: DAF XF 430 FTT 6x4 Tractor specifications.....	68
Figure 44: Schmitz Cargobull semi-trailer .....	68
Figure 45: Schmitz Cargobull semi-trailer specifications .....	69
Figure 46: Relation between wheels speed and engine speed.....	78
Figure 47: Information about the driveline of MX-13 engine .....	79
Figure 48: Dimensions of DAF XF 30 used to calculate frontal area .....	79
Figure 49: Litres of diesel combusted in N-121-A and A-15 in defined conditions.....	83
Figure 50: Drag coefficient in fluids with Reynolds number approximately of $10^4$ .....	84
Figure 51: Litres of diesel combusted in N-121-A and A-15 with empty semi-trailer....	86
Figure 52: Litres of diesel combusted in N-121-A and A-15 with empty semi-trailer....	87
Figure 53: DAF LF 150 model and its features.....	88
Figure 54: Litres of diesel combusted in N-121-A and A-15.....	89
Figure 55: Fuel consumption in A-15 for different truck dispositions .....	90
Figure 56: Fuel consumption in N-121-A for different truck dispositions .....	90

**Annex figures:**

Annex figure 1: Protected areas in Navarre (Source: Government of Navarre).....	104
Annex figure 2: Distance of a protected area measured with SITNA tool .....	105
Annex figure 3: Distance of a protected area measured with SITNA tool .....	106
Annex figure 4: Distance of a protected area measured with SITNA tool .....	106
Annex figure 5: Distance of a protected area measured with SITNA tool .....	107
Annex figure 6: Distance of a protected area measured with SITNA tool .....	107
Annex figure 7: Distance of a protected area measured with SITNA tool .....	108
Annex figure 8: Distance of a protected area measured with SITNA tool .....	108
Annex figure 9: Distance of a protected area measured with SITNA tool .....	109

**Tables:**

Table 1: Externalities caused by different transportation modes (Demir et al., 2011) . 23

Table 2: Fuel consumption for different truck manufacturers (Source: transportenvironment.org) ..... 29

Table 3: EU emission standards for heavy vehicles (Steady-state testing)..... 32

Table 4: EU emission standards for heavy vehicles (Transient testing) ..... 32

Table 5: N-121-A accident statistics ..... 41

Table 6: Economic valuation of traffic accidents..... 43

Table 7: Total cost of N-121-A because of traffic accidents..... 43

Table 8:Reduction in cost per year because decrease of accidents..... 44

Table 10: Example of simplification of data because of use of a GIS..... 50

Table 11: Operating costs of N-121-A and A-15..... 57

Table 12: Calculation of external costs for A-15 following “Handbook on the external costs of transport” ..... 62

Table 13: Calculation of external costs for N-121-A following “Handbook on the external costs of transport ..... 62

Table 14: Coefficients of emission functions for heavy goods vehicles with gross vehicle weights from 16 to 32 tonnes (MEET)..... 72

Table 15: Coefficients of gradient factor functions for heavy duty vehicles 16t<32t(MEET)..... 73

Table 16: Coefficients for load correction functions for HGVs from 16 to 32 tons (MEET) ..... 74

Table 17: Gear ratios for MX-13 and recommended RPM band..... 78

Table 18: CO2 emissions per litre of diesel burnt according to different sources in literature..... 82

Table 19: Litres of diesel combusted in N-121-A and A-15 in defined condition ..... 83

Table 20: Drag coefficients for different truck types ..... 85

Table 21: Litres of diesel combusted in N-121-A and A-15 for different geometries with their drag coefficients in Comprehensive method..... 85

Table 22: Figure 51: Litres of diesel combusted in N-121-A and A-15 with empty semi-trailer ..... 85

Table 23: Litres of diesel combusted in N-121-A and A-15 with empty semi-trailer..... 86

Table 24: Litres of diesel combusted in N-121-A and A-15..... 89

**Annex tables:**

Annex table 1: Equivalence factor between heavy and light vehicles in Guide de Bruit’s ..... 100

Annex table 2: L<sub>aeq</sub> calculation for towns in N-121-A..... 102

Annex table 3: L<sub>aeq</sub> calculation for towns in A-15..... 103

Annex table 4: Protected areas close to N-121-A and A-15..... 105

# 0. MOTIVATION

The motivation of this project is making an environmental impact analysis of two infrastructures (N-121-A national road and A-15 motorway) in order to decide which one of them is the most appropriate for road freight transportation, considering the environmental impact caused by the freight vehicles which use them. For this purpose, some emission calculation models will be used which are contained from (Demir et al., 2011) article. In order to do a viable comparison, different parameters will be obtained as the fuel consumption or the  $CO_2$  emissions (one of the main pollutants in road transportation).

This problem is very complex as many variables need to be modelled and taken in account. As a result, a model has to be built in a way that it is not too complex to be solved but enough rich to give an insight of the reality. Main parameters that affect fuel consumption and consequently emissions are the gradients of the roads and speed restrictions because of road features (tunnels, intersections, crossing towns...).

In order to solve this problem and definitely reduce the consumption of  $CO_2$  emissions, it is very important to have a good operational planning. For this purpose, estimation models need to be incorporated to the planning methods. Different analytical emission models differ in their ways of estimation of the fuel consumption and emissions, or in the parameters taken in account. This study's importance and main motivation relies in the application of these analytical models in order to solve problems in a real environment and how these models need to be adapted to the challenges that appear when trying to convert experimental data into numerical values. As a result, decisions taken in infrastructure planning are more coherent and follow established patterns. As stated before, two models contained in (Demir et al. 2011) article will be used, and its results will be compared for heavy vehicles with different characteristics.

Solving this infrastructure problem will allow knowing which of the routes is more efficient both economically and environmentally. This implies a more efficient use of resources by road transportation companies operating in northern Navarre roads. In a world where the lack of non-renewable energy sources is increasing every year and taking in account all the negative externalities caused by road freight transportation (negative effects in third parties not implied in the activities), it is very important to do these calculations and taking responsible decisions related to this issue.



# 1. INTRODUCTION

This study is focused in freight transportation, one of the main activities in worldwide economy nowadays. Consumerism has caused the consumption level to be higher and globalization that the wishes of customers are similar in different countries. As a result, goods need to be transported from the country where they are produced in developing countries, many times in eastern Asia, to where they are consumed. Technological progress and development of innovation and pursuit of faster and cheaper services for freight transportation have also reinforced this trend.

Goods are transported via plane or boat in a first stage until the loading docks, but later need to be transported via road in order to reach their final destination. In this context, road freight transportation is very important because it allows reaching destination that other transportation nodes cannot reach. For instance, in some small countries as Malta and Cyprus road freight transportation is the only possible mode as they do not have a railway network.

However, even if freight transportation is related to economic growth and development and is one of the key sectors in the economy it also causes some negative externalities, including irreversible changes affecting the natural environment. It also affects the life quality of the society, by damaging the human health: premature mortality and diseases, lung cancer or cardiovascular and respiratory diseases caused by particulate matter. These effects are aggravated in cities as more population and traffic is concentrated there.

## 1.1. Sustainable Transportation

Nowadays, economic growth and global trade relations are leading to a very big increase in transportation activities especially in industrialized countries. This development is also causing many negative externalities such as noise, air pollution, accidents or human induced global change. GHG emissions (which include CO<sub>2</sub>, CH<sub>4</sub>, N<sub>2</sub>O, SF<sub>6</sub>, HFCs and PCFs) related to transportation were in 2010 the 14% of the global and their grown since the 70s has been bigger than in any other sector.



Figure 1: Sustainable Transportation

Sustainability has usually three pillars which are ecology, economy and society. A sustainable transportation system was defined in 2006 by the Renewed Sustainable Development Strategy of the European Union as one that “meets society’s economic, social, and environmental needs whilst minimizing its undesirable impacts on the economy, society, and the environment”. Some activities which can contribute to

sustainable transportation are developments in vehicle technology, new organizational forms, investments into infrastructure, internalizing of external cost or customized algorithms for transportation planning.

Between 1995 and 2015 growth in total freight transportation has been of 23.6%. The portion of road transportation has increased during this period from 45.3% to 49%. Regarding the number of accidents in 2015 26.134 persons were killed in road accidents which supposed a decrease of 66.2% with the rate of 1990, but 0.7% more in 2015 than the rate in 2014.

Another concept related to this topic and mentioned before are externalities. Externalities is a situation in which one person's behaviour affects the welfare of another in a way that is outside of existing markets. They can be positive or negative. According to Demir et al. (2015) these are the main externalities related with freight transportation: Local (carbon monoxide or ozone) and regional (sulphur emissions which lead to acid rain) air pollution, global GHGs, water pollution, noise pollution, congestion, accidents and land use.

According to Ruzzenenti and Basosi's (2017) improvements were done in transportation sector by 15% between 1990 and 2010 with a grown in service demand almost twice as much. There is relation between economic growth and growth of freight transportation sector. There is also a rebound effect, which means that gains in energy consumption can offset expected energy efficiency gains.

#### **1.1.1. Economic Vision of Sustainable Transportation**

Transportation is related to economic growth, usually in phases of economic growth also comes an increase and development in transportation. Transportation expenditures for households represent nearly 20% of GDP in recent years. The growth of transportation activity has some drawbacks too as it is related to many negative effects as traffic congestion, air pollution, greenhouse effect gases (GHG), traffic noise, and traffic fatalities or injuries.

These negative effects must be evaluated in terms of social and economic costs they generate and compared to social and economic benefits generated, in order to implement the best possible policies. Regarding environmental economic perspective, if for a certain activity social benefits are higher than social costs, then this activity should be promoted by authorities. By the contrary, if social costs are higher than benefits, households and firms should be limited by regulators. Public policies should minimize external costs, which are the ones generated by individuals but affect the society as a whole. Comparison between social benefits and costs needs to be done in a common scale, for these physical impacts of activities have to be converted into economic values for the performance of cost-benefit analysis.

As said before cost-benefit analysis determines if an activity improves or decreases economic welfare for society. For doing so there are two approaches, the first one is incremental.  $W(q)$  is the economic welfare or difference between total benefits  $B(q)$  and costs  $C(q)$ , where  $q$  is the level of activity.

$$W(q)=B(q)-C(q) \tag{1}$$

For maximizing the welfare level, you need:

$$\frac{\partial W(q)}{\partial q} = 0 \rightarrow B'(q) = C'(q) \tag{2}$$

The second principle deals with social impacts (costs and benefits) which are the sum of both private costs/benefits with external ones. For example, applying it to this study, if you travel with a heavy vehicle from point A to point B passing through a forest, you will cause some external costs to the whole society as the forest will be more polluted, more noise disturbing animals... As a result, there is a market failure, resources are not allocated in an efficient way.

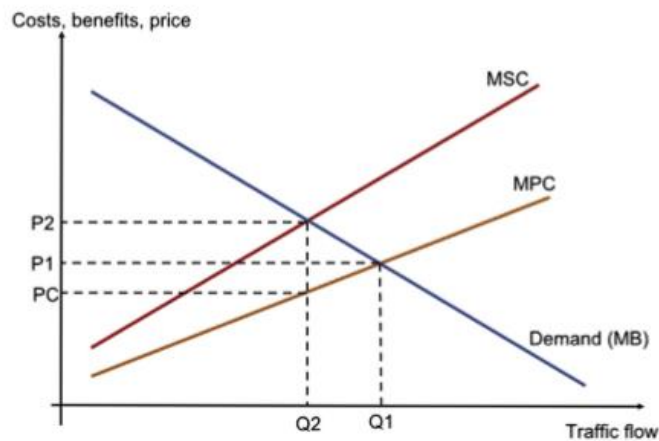

Figure 2: Costs and benefits of freight transportation

As we can see in the graph, there are two possible equilibrium points in decision making. The point Q1 represents the privately optimal level of output. In this case external costs caused to environment are not considered (in the case of heavy vehicles GHG emissions, pollution, noise...). As a result, social welfare is negative, as social costs are much higher than social benefits. The point Q2 represents the socially optimal level of output as it takes in account not only the marginal private costs (MPC) but marginal social costs (MSC), (sum of marginal private cost and marginal damage).

For doing cost-benefit analysis monetary values need to be given to both private costs and external costs. In the case of private costs, it is easy as information is given by transport markets. However, in the case of external costs as impacts have no market effects, individual preferences are the method to estimate them. If people suffer from environmental nuisances, they would be able to decrease some amount of money they receive in order to diminish them. In this concept there are two approaches. The first one is the willingness to pay or paying a certain amount of money in order to avoid certain level of nuisance. The second one would be the opposite, willingness to accept

which means that individuals are asked for an amount of their income level in order to be able to increase the damage level they generate.

The total willingness to pay and total willingness to accept are used to determine the total economic value of a good or service (giving monetary values). As a result, this total economic value is defined as the maximum amount of money an individual wants to sacrifice (Willingness to pay) for the existence of a good or the minimum amount of money an individual asks as a compensation for the non-existence of it (willingness to accept). The individual might be paying some money in order to be able to use the good (use value), for having the option of using it in the future (option values) or just to ensure its existence (non-use value). This last can be done in order to ensure the good for future generations (bequest value) or just to ensure the existence of the good (existence values).

In order to determine WTP and WTA two methods are used, stated preference methods and revealed preference methods. In the first one a survey is used with hypothetical questionnaires where participants state their maximum WTP and minimum WTA. For second one, it can be done both via hedonic pricing (inferring economic values to non-market effects from observed behaviour) or travel cost method (if people have to stand some transportation costs to enjoy to an amenity related to a non-market good, then its willingness to pay for this good is equal or higher this transportation costs).

## **1.2. Road freight transport**

It was mentioned before that the topic of this project is freight transportation, but more specifically road freight transportation is treated. Road freight transport is the physical process of transporting cargo by road using motor vehicles. Road is defined to be a lane/route between the point of departure and the point of destination.

In comparison to other types of transport system such as sea and air, the maintenance cost of roads is cheaper. In case of rural areas where other modes of transportation are not available road freight can be the only way of transport.

### 1.2.1. Characteristics of road Freight Transportation

Road transportation is defined by having low barriers of entry and low start-up expense. Expense is low because roads generally are public and constructed by government. Barriers of entry for transporters are low because usually they only need to purchase a vehicle



*Figure 3: Road freight transportation*

and obtain some certification, being able to enter the market then. In Spain nearly 75% of long-distance drivers are own operators (Arruñada et. al 2004).

The roads itself can have different features; the most basic road is a traffic lane with just carrying traffic in one direction of travel. The minimal road configuration is two lanes, with one lane for each traffic direction. Then bigger roads are dimensioned by multiples of two: four-lane-roads, six-lane-roads... A problem that sometimes arises in respect to maintenance and construction of roads is that funding comes from indirect taxes on for example fuel rather than from direct taxes.

Moving on to the road vehicles, they have the following characteristics: they are almost manually steered, independently powered, supported by rubber tyres which are pneumatically inflated, in road surfaces without guidance mechanisms and with displayed lights as the only source of communication. Most common road vehicles have two wheels. Regarding their sources of power, the most common one is internal combustion engine. For small cars and personal transportation gasoline motors are the most common ones, they are lighter, less expensive and more capable of starting in cold weather circumstances. In diesel motors (fuel is ignited without a spark) the cost is cheaper but it does not ignite well for low temperatures and the carbon content per energy ratio is higher. Other alternative fuels are liquefied gas and biofuel.

With respect to vehicles with more than 4 wheels they can be either articulated or combination vehicles. Articulated ones usually are buses which have a main body of four wheels and a permanently attached trailer of two wheels. Combination vehicles are the ones important for this study, as tractor pulling a semitrailer is the typical disposition for long distance road freight transportation. The tractor is where the driver's cab is and it is the power unit. It has also a steering axle and or two driving axles. Many long-distance tractors have sleeping berths where drivers can have rest during mandatory breaks. Whereas in the United States there is a limit for trailer length of 48 feet (14,63m), in Europe many vehicle combinations are allowed in order to meet with local conditions. A controversial topic in freight transport is related to long combination vehicles or LCVs as they attach two or three standard 40-foot trailers and have advantages in terms of economy, but issues related to security.

Regarding the design of road transport service, sometimes road transportation operates with a schedule and in this case the planning is similar to railway planning system. However, generally road transportation does not follow timetables especially in long distance travel and operate in demand like a taxi service would operate. In economic wealth periods owner-drivers can show market power by refusing some orders if the conditions are not the ones expected so as a result it is more difficult to make an optimization in this kind of transportation.

This are some of the main road transportation advantages compared to other transportation modes:

- It is a relatively cheap mode of transportation.
- The density of road network is high.
- Transport time is shorter.
- Routing and time scheduling are flexible.
- Door-to-door service is provided.
- It can be adapted to the demand of customers.
- Damage of goods are low during the transportation.

### 1.2.2. Types of vehicles

There are different types of trucks for road transportation depending of the freight, the volume, the weight and the itinerary.

Structural formats of trucks:

- **Rigid:** In the driver's cabin and the trailer or load area are in the same indivisible structure. They are used generally for transportation in urban areas and package delivery.
- **Articulated:** They are formed by two rigid parts. The cabin and the load area are united thanks to an articulation, so they are more versatile for different sizes and types of load. The trailer is formed by a semitrailer and cabin which has a function of propelling the semitrailer, both of them can be separated.
- Types of trucks depending the type of load they transport:
- **Closed:** The load area has rigid enclosures, so the loading and unloading are only done in the back aperture.
- **Open platform:** This type of load area is very versatile and it can even be adapted to different types of freight because they can incorporate some type of closure, cover or sides in order to avoid the movement of the load. It is usually used for construction materials or bulk products.
- **Tautliner:** Or truck with walls closed by canvases, they allow an easier loading and unloading from both sides.
- **Frigorific, isothermic or refrigerated:** Used for freight transportation that need a controlled temperature, as perishable food.
- **Tank:** They contain a tank for the transport of liquid or gas elements.

Types of trucks depending in their capacity:

- **Light:** Between 500 kg y 2.5 tons.
- **Lightweight:** Between 2.5 and 3.5 tons.
- **Semi-lightweight:** Between 3.5 and 4.5 tons.
- **Medium:** Between 4.5 and 5.5 tons.
- **Semi-heavy:** Between 5.5 and 7.5 tons.
- **Heavy:** Between 7.5 and 9 tons.
- **Extra-heavy:** Between 9 and 11.5 tons.
- **Ultra-heavy:** Between 20 and 23 tons.
- **Super-heavy:** Between 40 and 250 tons (also known as tracto-trucks).

### 1.2.3. History of road freight transportation

Initially in civilization history people and animals provided the first sources of power. Later load-carrying vehicles were developed, from dragged branches, through to sledges, to wheeled vehicles. An important and unique event for this was the invention of the wheel, and then of the axle which led to the development of carts and wagons and then of steerable wagons. Despite these inventions, transport of freight by land was slow and inefficient. Industrial Revolution was the event that caused the factors which led to this to change: better roads, the power of steam first and later of internal combustion and the effectiveness of pneumatic tyres and well-designed suspension systems.

In this context, the evolution of trucks is a significant landmark in the history of road transportation. After the first carriages pulled by horses and the transport of load by animals, the next step were steam vehicles. The first of them was designed by Nicolas-Joseph Cugnot in 1769, with this type of technology having a great impact in freight transportation in the first decade of XIX century.

In 1885 Karl Benz invented what is considered to be the first truck in history, as it had an internal combustion engine, and only a year after of it Gottier Daimler constructed another truck. Later, some of Benz's trucks were modified to be converted in the first buses by the company Netphener. After that both Renault and Peugeot created their own versions, main of them had engines of between 2 and 4 cylinders and a load capacity of between 1,500 and 2,000 kilos.

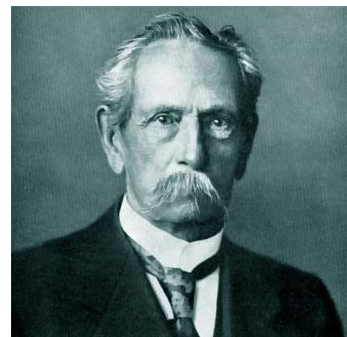

Figure 4: Karl Benz (1844-1929)

The First World War was a big push for the construction of these vehicles, by that time they already included rubber tyres, electric ignition and brakes, closed cabs and electric illumination. However, diesel motors were not adopted

for trucks until the mid XX century. In Europe they started becoming frequent after 1930s having the complete market share in 1950, whereas in United States this change was slower and still remained some gasoline trucks in the 1970s.

Freight transportation by road continues being the preferred one thanks to the flexibility that trucks allow. It is a quick vehicle, that can offer a door-to-door service, it can change the route if necessary, guarantees security and adaptability, its locatable and because of all the previous reasons it results more economic.



*Figure 5: One of the first internal combustion trucks by Daimler in 1896*

Nowadays, more than 95% of freight in Spain is transported by road, is the ancestral inheritance of communication routes, the roads and paths built since Middle Age, the national roads built during the XVIII and XIX centuries, the network of asphalted itineraries and the plans of Motorways and Infrastructures, that allowed ensuring connections between France and Portugal. Despite the fact that there is still infrastructure to improve, Spain has nearly 200,000 thousand kilometres of rods that allow connecting with neighbour countries and in consequence, consolidating the growth of different sectors.



## 1.2.4. Situation of road freight transportation

### 1.2.4.1. Current situation in Spain

Road freight transportation is a very important pillar in Spanish economy. This happens because it is being more demanded thanks to the increase of external commerce. A bigger volume of deliveries is being demanded, especially with destination to other European Union countries.

According to *“Observatorio Nacional del Transporte y la Logística en España”* the transportation sector represents 2.9% of national GDP and 94% of tons that are travelled by road. These data, show the importance of this activity for the correct functioning of the economy.

Even if the crisis has caused the disappearance of many small companies it is still a very fragmented sector, even if the trend shows an evolution to a business fabric more centralized in big companies, both with own fleet or dedicated to outsourcing.

Nowadays, there is a high increase in the price of fuel and tolls of some motorways which leads to a complicated situation for drivers. Especially in the case they are self-employed because many times these costs are not taken in account by clients so their exploitation costs increase.

Governmental legislation is an element always being under debate in this sector. In a national level there has been new legislation referred to the sector as the *“Reglamento de Ordenación de los Transportes Terrestres (ROTT)”* which came into effect the 21st of February of 2019 and regulates important aspects in the business as:

- Access to the sector
- Training of the workers
- Fees
- Transfer of authorizations for transportation

The freight road transportation is having an evolution to digital technologies, which is incorporating to more and more professionals of the sector: Trucks with geo-positioning and navigation systems that allow knowing traffic incidents and optimizing routes, mobile applications as On-Truck for load and fleet management, traceability systems that allow knowing the state and the location of the load etc.

In year 2020, with the Covid-19 crisis causing confinement of the population and the closure of other economic sectors road freight transportation has reinforced its importance. There has not been any limitation for the activity of transportation, logistics and courier services, that have been considered essential sectors for guaranteeing population's supply. Moreover, carrier services have avoided the propagation of the virus as when they ship products to residences they diminish transit of people.

#### 1.2.4.2. Current global situation

If at a national level road freight transportation is a very important sector needless to say at an international level. The global road freight transportation market size was valued at USD 2,811.7 billion in 2018. Global road freight transportation is a highly fragmented market and there is great amount of global and regional players in it. Between the greatest operators in the market of road freight transportation the next ones are included: Cargo Carriers Limited, Schenker AG, Kuehne + Nagel International AG, CJ Logistics Corporation, DHL Global Forwarding, Kerry Logistics Network Limited, TNT Express, CEVA Logistics, GEODIS SA, DSV Panalpina A/S , Overland Total Logistics Services (M) Sdn Bhd., Nippon Express, and GEFCO S.A.

In a European level in 2015, the share of road freight transportation between road transport vehicles expressed in ton-kilometres was of 75.8%. This share has remained stable in the past years only with some small fluctuations. For rail transport, the percentage for the same year was 17.9%, while for inland waterway transport the percentage was of 6.3%.

Moving on to international legislation, mobility legislation package by the European Commission continues without seeing the light. The European Union of Road Freight Drivers defends the application of measures that ensure loyal competition and social protection, professionalization for access to light transportation and regulation of displaced workers and rest times and the obligation to use electronic tachograph. However, there is not still the necessary consensus for its approval.

Some negative effects are also affecting international road freight transportation. As mentioned before, road freight transportation is also related to some negative externalities caused by fossil fuel consumption. Not only this but with its not renewable nature the resources of oil will finish. With transport representing 50-60% of world's oil demand if present global GDP growth trends remain the increase of fossil fuel consumption will be of over 100% in 2040. In this context, we are in a scenario where fossil fuel demand is increasing but its supply is decreasing. As a result, global road freight transportation operators have to start a transition to cleaner renewable energy sources.

#### 1.2.4.3. Future trends

Analysing the future trends of road freight transportation, its market is expected to have a great amount of growth during the up-coming years (2020-2030). Factors that accelerate this are rapid urbanization, growing of the population and extended e-commerce industry around the world.

Global road freight transportation is categorized according to the industries: Food and beverage, chemical, healthcare, oil and gas and others. Due to this industry's expansion, oil and gas category is expected to lead the market during the forecast period. Food and beverage industry is the category expecting the highest growth during 2020-2030. Global population is rising and economy is growing in developing countries leading to an

increase in the income of middle-class population. This income increase is increasing the demand of eatables whose market is expected to benefit during the forecast period.

Based in the vehicle type, if the road freight transportation market is divided into light commercial vehicle and medium and heavy commercial vehicle. In the forecast period, the market is expected to grow faster in the light commercial vehicle category, mainly because of the adoption of these vehicles for transportation of food and beverage and other consumer products.

From a geographical perspective, Asia-Pacific (APAC) region is expected to dominate the market during the next years. Countries as China and India, with rising population and favourable government policies regarding e-commerce and other industries, are expected to lead the growth. Moreover, developing countries in this region are investing heavily in port development which increases its cargo handling capacity. According to the Ministry of Shipping of the Indian Government, more than 90% of India's commercial trade is done via the sea and by 2025 the cargo traffic Indian ports is expected to be of approximately 2500 million metric tons per annum (MMTPA) compared to the current one of 1500 MMTPA.

Industrialization and adoption of Industry 4.0 are the major factors that will cause growth in the road freight transportation market in the following years. However other negative factors are expected to hamper the road freight transportation market growth over the next years such as rising carbon emissions due to the use of diesel fuel in road transportation and increase in number accidents. Sources of U.S. department of Transportation claim that in 2017 4,657 large trucks were involved in fatal crashes. 57% of all this fatal crashes involving large trucks occurred in rural areas, 27% occurred on interstate highways, and 13% on rural interstate highways. Freight transport also faces a big setback from the inclement weather, deteriorating road condition, and traffic congestion, joined with the challenges of long-distance driving.

#### **1.2.5. Cost calculation of freight transportation**

Road freight transportation is an essential mean for many companies doing commercial transactions. This is a consequence of the economic and time savings, especially in the national ambit. In Spain 95% of freight transportation is done in road, in front of just 2% which is made by railway. In the case of transferring goods towards different countries of European Union, many companies choose terrestrial road transportation. The cost is greater than in the case of the train, but it has an advantage in its speed, as in railway transportation wagons are coupled and decoupled in many times during the routes.

As transport activity is one of the most important ones in the supply chain of main companies, optimization of its cost is crucial. Market is getting more globalized and customer demands are changing over the time. Supply chains are becoming more

international which leads to bigger search of this efficiency search. Data shows that transportation activity means 30% of global supply chain costs and from the total ratio of freight transportation 78% corresponds to road transportation.

There are three different alternatives in order to provide transportation service:

- Given by own vehicle and own driver: It is there most typical set-up, because companies have as their most important strategic aim the maximization of utilization of resources.
  
- Given by rented vehicle but own driver, used in cases in which:
  - The companies have not sufficient vehicle resources to fulfil clients' orders, but the carrier wants to take on the transport task:
    - The clients' orders cannot be completely fulfilled using their own vehicles.
    - Special vehicles are required (chemicals, frozen goods, dangerous items...)
    - Carrier's vehicle out of order due to breakdown or accident.
  - The task has to be realized by the carrier because the client is a strategic partner.
  - Maintenance cost of vehicle is higher than renting.
  
- Given by rented vehicle with external contract driver: Is a common practice which is applied by carriers and forwarding agents in order to reduce costs and increase profit. Work is transferred to external carriers instead of completing it internally. Some cases where is applied:
  - Cases in which the companies have not sufficient vehicle or human resources to fulfil clients' orders in time.
  - Carrier's demand only can be fulfilled with special vehicles.
  - Outsourcing partner with lower labour costs and greater skills and knowledge.

### 1.2.6. Negative Externalities Affecting Road Transportation

In this part main negative externalities affecting transportation will be discussed.

#### 1.2.6.1. Air pollution

Emissions can be classified based on the impacts on local (smaller than 500 km diameter), regional (greater than 500 km) or global (terrestrial scale). They can affect people, vegetation, global climate and materials. Sources for local pollutants are particulate matter (PM) in different sizes/compositions (fine particles are the most dangerous ones as they can be easily inhaled and penetrate into the



Figure 6: Air Pollution

lung) and gaseous air pollutants (associated to some diseases as asthma in children, respiratory diseases, heart diseases, cancer or premature death in adults).

Local pollutants are classified in two groups.

**Conservative pollutants:** These pollutants are harmful because they have a direct impact in environment and health. Examples are carbon monoxide CO when it is found in high concentrations in cities (reduces blood's oxygen taking capacity), VOCs and NOx which increase probabilities of respiratory or heart diseases and damage plants, waterways and ecosystems.

**Secondary pollutants:** These kinds of pollutants are caused by conservative pollutants. For instance, CO, VOCs and NOx are precursors to ozone formation ( $O_3$ ).

Regional impacts are derived from acidification and ground level ozone.

#### 1.2.6.2. Greenhouse gases

Cause atmospheric changes and climate disruptions which are harmful for environments and have health risks. They are not considered as pollutants as use, however, they possess and absorb radiation in the thermal infra-red range in the atmosphere and increase temperature of Earth. Their impact is assessed in this way, by the increase in temperature in Earth in the last 100 years. Main GHGs in transportation are carbon dioxide ( $CO_2$ ), methane ( $CH_4$ ), nitrous oxide ( $N_2O$ ), ozone ( $O_3$ )...

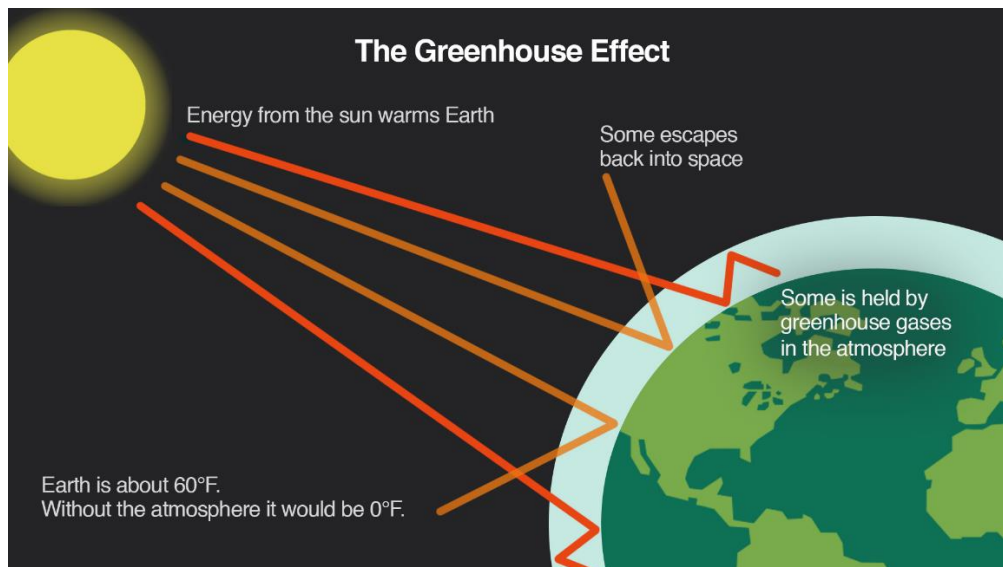

Figure 7: Greenhouse Effect (Retrieved from [climatecentral.org](http://climatecentral.org))

#### 1.2.6.3. Noise pollution

Noise problems related to transportation arise when people have to deal with it frequently. When the noises are severe or the duration of the noises are long some health problems occur (as stress, sleep disturbance, cardiovascular disease or hearing loss). Noise can be measured in different ways of weighted decibels (dBA, dB(A) or dB(a)) in volume terms. Some other factors have to be considered too as pitch, frequency,

duration or variability. The effects of the noises in human beings are different regarding their level. Low levels of noise (below 60dB) even acceptable for short duration can harm human health if they are present long enough. Moderate noises can cause cardiovascular diseases or result in nervous stress reactions. Finally, noises above 85dB can cause very big hearing damages. Transportation noises can disturb people's sleep (especially those living near highways) and people living close from transportation hubs is damaged frequently. Having a monetary estimation of these impacts is complicated though because of non-linear characteristics of it. This can be achieved by hedonic valuation methods or contingent valuation methods.

#### 1.2.6.4. Water pollution

Freight transportation can cause both indirect and direct water pollution. Directly water pollution can happen in marine transportation (no road transportation). This can happen when there is a discharge of ballast water from marine vessels, if ballast is not apart from the cargo then seas and coasts are polluted with oil. Water quality can be affected too with air pollution (for example if it is derived through acid rain).



Figure 8: Water pollution

#### 1.2.6.5. Congestion

Congestion in transportation network is present when entities compete individually for a limited capacity. It causes different negative effects as increase of travel times, operation costs and unreliability. Direct impacts include the time costs generated to other agents and indirect impacts are more variate as increase fuel cost, air and noise pollution or stress.



Figure 9: Traffic congestion

#### 1.2.6.6. Accidents

Costs of emergency services, delay of traffic and costs to families in pain are included within externalities of accidents (damages to people, vehicles, freight and infrastructure are not included because are direct effects). Oil spills and release of chemicals in trucks accidents or train derailments can release toxic chemicals dangerous for health.



Figure 10: Traffic accidents

### 1.2.6.7. Land use:

Transportation affects land use, directly via the land used for the facilities and indirectly affecting locations and designs for infrastructure planning. Some examples include the replacement of natural areas with infrastructure, visual damage in landscapes, high traffic that denies crossing roads or species loss.

As it can be observed in this externality compilation, the intensity of externalities is greater for road transportation than for other kind of transportation.

<b>Negative externalities</b>	<b>Road transportation</b>	<b>Rail transportation</b>	<b>Marine transportation</b>	<b>Air transportation</b>	<b>Pipeline transportation</b>
Air pollution	***	**	**	**	*
Greenhouse gases	***	**	**	**	*
Noise pollution	***	**	**	**	*
Water pollution	**	*	***	*	*
Congestion	***	*	*	*	*
Accidents	**	*	*	*	*
Land use	**	**	*	*	*
*Low **Medium ***High					

*Table 1: Externalities caused by different transportation modes (Demir et al., 2011)*

## 1.2.7. Administrative features of road freight transportation

### 1.2.7.1. Contract of freight road transportation

The contract of freight road transportation is the document by which one person (called carrier, driver or shipping agent) accepts an obligation with another person (sender or docker) to conduct the transfer of the products until the moment in which are sent to the final client or recipient of the delivery (designed on the contract) in an exchange of some economic reward and with the use of a vehicle which has own traction (truck, car etc).

Additionally, proof has to be left about transportation price and costs that are expected to incur, the place and the date in which the goods were received by the driver and in which is expected to deliver the products to the correspondent client. The contract needs to have also a detailed description of the goods (number of packages, type of products etc) and it has to appear who takes charge of shipping fees (owed or paid shipping fees).

Moreover, there is the possibility of having two different systems referred to transportation of goods via road: dispatch transportation (transport service contract) and continuous (continuous transport contract). Dispatch transportation refers to the deliveries accomplished in sporadic occasions, which means it is not an activity which is

performed continuously but an exceptional delivery. In contrast, continuous transportations are those conducted with some periodicity, that is, different deliveries with a short due date between one delivery and another.

Another point to be considered is that is not necessary the road freight contract to be written, however for reasons of legal security and possible future problems it is recommended to leave proof of it in writing. By the same way, the continuous transportation contract needs to be formalized in the moment that any of the parts demands it and can be signed by physical people or legal entities.

1.2.7.2. Waybill:

The waybill documents totally or partially the content (terms and conditions) of the transportation contract. Even if is not an indispensable document and its lack or irregularity does not involve the non-existence or cancellation of the transportation contract, any of the two parts is in its right to ask the other party the formalization of this contract. In the case one party denies it can be considering as a renounce of the contract. In continuous deliveries it can be required the emission of a waybill per shipment, in which must stipulate details and conditions of the contract signed before by the two parts.

This document must be signed by the two parts and it is necessary to emit three copies (the first one for the docker, the second close to the shipment and the third for the driver).

<b>Shipper Information</b> <input type="checkbox"/> Domestic <input type="checkbox"/> Int'l Shipments <input type="checkbox"/> Consignment Declaration of goods <input type="checkbox"/> LTL <input type="checkbox"/> LK BLD <input type="checkbox"/> Round Declared Value for Customs Declared Value for Customs		<b>ANA CARGO EXPRESS</b> <b>Air Waybill</b> Not Negotiable 01234567890	ORIGIN <b>SG SIN</b> DESTINATION <b>JP TYO</b>
<b>Shipper</b> Customer Code: SA0000 -001 -001 Company Name: ANA CARGO EXPRESS SINGAPORE PTE LTD Address: 133 CECIL ST. #10-03 KECK SENG TOWER SINGAPORE City: SINGAPORE Phone No. (Ext. No.): 069535 / 6224-1535	<b>Receiver</b> Customer Code: SA0000 -001 -002 Company Name: OVERSEAS COURIER SERVICE CO LTD. OCS TYO Address: 2-9-13 SHIBAURA City: MINATO-KU TOKYO Country: JAPAN Phone No. (Ext. No.): 1088701 / 03-5476-8109	<b>Payment</b> <input type="checkbox"/> Collect <input type="checkbox"/> Prepaid <input type="checkbox"/> Other Dimensions: 1 x 1 x 0.1 Surcharges: Our staff use only.	

Figure 11: Example of a waybill

1.2.7.3. Transportation of dangerous freight via road

The docker is the person with the responsibility to tell the driver in the contract the nature of the danger and the recommended preventive measures for his security. Some of the dangerous goods that can be found are: flammable liquids, explosive objects, gases, flammable solid materials, toxic materials, radioactive materials or auto reactive materials.





Figure 12: Kinds of dangerous loads

#### 1.2.7.4. Responsibility of the driver

In the transportation contract, the loader has not an only obligation of providing a service (of freight transportation) but also is obliged to obtaining a result, which means it has to realize the transfer of the goods in the conditions accorded between the parts and without the goods suffering any kind of damage or worsening.

In this sense, the driver has the duty of responding economically in the case that some loss is produced or in the case of partial or total damage of the good since they are put in the disposition of the driver until they are delivered to the corresponding recipient.

Equally, the driver will be responsible too in the case a delay is produced in the delivery of the goods and has to respond to the loss caused by this situation. Moreover, the character of responsibility provided by this law is imperative, which means that parts cannot limit obligations nor avoid them.

#### 1.2.7.5. Legal and administrative requirements for the driver

In order to be able to offer this kind of services, generally the driver needs to be in possession of an authorisation of public transport of goods (public transportation card MLD or MLP) which is issued by the competent authority of each autonomous community in which this consent has been established (normally in its legal address). These permissions establish the possibility of performing public transportations in the whole state scope, however, in some communities, authorizations are given too in an autonomic scope. By the same way, the transportation company needs to have minimally a physical person in the function of transportation manager with a professional competence transportation certificate emitted by the administration. Before signing the last contract of inland transportation of goods, the driver needs to be aware of the procedures carried out and about the requisites, ensuring that fulfils all the legal and administrative formalities. Once the contract has expired, during the transfer of the goods, the driver needs to have with himself/herself all the necessary documentation (e.g. waybill, public transportation card, shipment documentation etc).

TRANSPORTATION CARD			
VALIDA HASTA:		PRÓXIMO VISADO:	
TITULAR		CI/NIF	PROVINCIA
DOMICILIO FISCAL		LOCALIDAD	
CLASE Y AMBITO	NI DE TARJETA	FECHA AUTORIZADA	MATRÍCULA
PLAZAS	RESIDENCIA AUTORIZACIÓN	PROVINCIA AUTORIZACIÓN	

Figure 13: Transportation card MLD

#### 1.2.7.6. Transportation inside or outside the European Union

In the case that the transportation of the goods by road is done in an international level, the required documentation will depend on the scope of the commercial transaction. If the transportation is carried out inside European Union, the exit custom office will require the document T (T1 for the communal transit of goods imported from non-EU countries and T2 for internal community transit). By the other hand, if the exportation is done to countries not belonging to the EU the required document will be the one of TIR (Transport International Routier) notebook. Thanks to this notebook, procedures are lightened and the length of the journey is shortened, because there are not necessary the inspections of the goods in the borders of the countries when being crossed. Additionally, for the getting the TIR notebook it is necessary to have a TIR certificate agreement, issued by the “*Dirección General de Aduanas e Impuestos Especiales*” (General Direction of Customs and Special Taxes) after passing an aptitude revision. As a result, this document declares the validity of the vehicle for performing international freight road transportation with a validity of two years.

#### 1.2.7.7. Applicable legislation

Inland road freight transportation is regulated mainly by law 15/2009, of 11<sup>th</sup> November, of the contract of inland freight transportation contract and the order FOM/1882/2012, of 1<sup>st</sup> August, by which general conditions are approved for the hiring of freight road transportations. By the same way, there are prone for application the international treaties ratified by Spain in the matter (especially the agreement of 29<sup>th</sup> May of 1956 relative to the contract of transportation of freight by road or CMR agreement) and the European Union normative. In which respects to these regulations, there are of application in the Commercial Code (in articles 50 and 63) in the case of commercial articles because of its object or subject the law 16/1987 of 30<sup>th</sup> July, of inland transportation ordinance and the Real Decree 1211/1990, of 28<sup>th</sup> September, by which it is approved the regulation of the law of ordinance of inland transportation.

#### 1.2.7.8. Legislation for rest and driving time

The legislation which regulates the rest, pauses and driving times in freight transportation is contained in two regulations:

- Regulation CEE 3821/85 of council, relative to control equipment of road transportation sector.
- Regulation (CE) 561/2006 of European Parliament and Council of 15<sup>th</sup> march 2016 relative to harmonization of determine dispositions of social subject in road transportation sector (which repealed the old legislation CEE 3820/85). Every driver who carries through any kind of road transportation are under both legislations, independently if it is public or private, national or international, or if the driver is Spanish or international. It does not matter either if the vehicle is loaded or not.

#### **Driving times:**

There is difference between daily, weekly and biweekly driving.

- Driving times in **daily working days**: The maximum driving time is of 9 hours. It can only be exceeded until 10 hours two days a week. After a maximum of 6 driving periods, the driver must stop for a week. In this case the working days do not count as calendar days, they are measured between the final of a rest time and the beginning of the following.
- Driving times in **weekly working days**: 56 hours of driving time in a week cannot be exceeded. In this case working days, count as calendar days.
- Driving times in **biweekly working days**: 90 hours of driving time in two consecutive weeks cannot be exceeded.

#### **Rest times:**

There is difference between daily, weekly and biweekly rest.

- **Daily rest**: As minimum the rest must be of uninterrupted 11 hours. There is also the reduced rest in which just 9 hours can be rested in the case that in the same day a rest of 3 hours has been done.
- **Weekly rest**: After driving for six consecutive days a rest of 45 uninterrupted hours has to be taken.
- **Biweekly rest**: Two rests need to be taken of 45 hours each. It exists also a reduced rest time of 45 hours one week and 24 hours the following.

## **Pauses:**

During the day the driver must:

- Stop for at least 45 minutes after having driven 4 hours and 30 minutes.
- A fractionated stop can also be done. In this case the driver stops for 15 minutes and then for 30 minutes, always taking in account the driving time of 4 hours and a half.

### **1.2.7.9. Gross vehicle mass:**

In Spain and in the rest of European countries there are some regulations about the weight of the trucks and their loads that need to be mandatorily fulfilled. If not, road safety crimes can be committed and be exposed to sanctions by traffic in the corresponding traffic controls. For this it has to be taken in account the gross vehicle mass (GVM) for inland transportation as well as the maximum weight authorized for trucks and lengths.

Every type of truck or trailer has a maximum authorised mass which varies depending in its axes and the distance between them. For example, in the case of having a fleet of 5 axle trailers, 40 tons of cargo could be transported, always having in account the limitations of other countries always that it is an international transportation. Apart from the gross vehicle mass, it has to be taken in account the regulation related to the maximum weight of the truck and its length.

### **Maximum authorised mass for trucks:**

- **Two axle trucks:** Maximum weight of 18000 kilograms.
- **Three axle trucks:** The maximum limit of weight is of 25 tons, arriving until 26 if the vehicle has an axis equipped with double tyres and automatic suspension.
- **Four axle trucks:** The limit is of 31 tons can be 32 if the truck is of two axes, twin wheels and a suspension of tyres.

Inland transportation has suffered important changes in the last months about their dimensions or maximum masses. The aim of this changes is to make of transportation a sustainable activity which respects more the environment as the time goes by.

Changes affect to trucks under the following circumstances:

- If aerodynamic improvements are carried out to improve consumption.
- If trucks powered by alternative energies are used (non-fossil combustibles).
- If the truck is multimodal of containers of 45 feet. In this case the length of the vehicle can be extended 15 centimetres.

### **1.2.8. Fuel Efficiency in trucks**

Truck emissions are growing faster than any other land transportation ones in the EU as trucks are only 3% of the vehicles in Europe but represent a larger amount of road transport emissions of 25%. If the current trend continues the trend for 2030 is that trucks will mean 40% of total road transport emissions. Principal reasons causing the

increase are the grown in demand for freight transportation and stagnation fuel efficiency of trucks.

Some changes have been carried out in the last 20 years with respect to trucks, the most important one regarding a reduction in pollutant emissions. Forced by EURO I-VI standards, truck makers have been obliged to reduce PM, NOx and other emissions in a drastic way. A EURO VI was introduced a tougher compliance regime came with it related to in-service conformity service. After these regulations real driving conditions and truck safety have improved. Trucks are nowadays fitted with emergency braking and stability control systems.

Safety and air quality improvements have been promoted by regulation. Manufacturers have helped by increasing the performance and comfort of their vehicles. A study carried out by ICCT (International Council on Clean Transportation) shows that engine power of trucks has had a steady increase since the mid-1990s. This increase in power has some positive points as an increase in the driveability of trucks but also negative ones as it also provokes a higher consumption of fuel. Even if new technologies have been applied in order to reduce fuel consumption, these improvements are not being implemented at all in new vehicles.

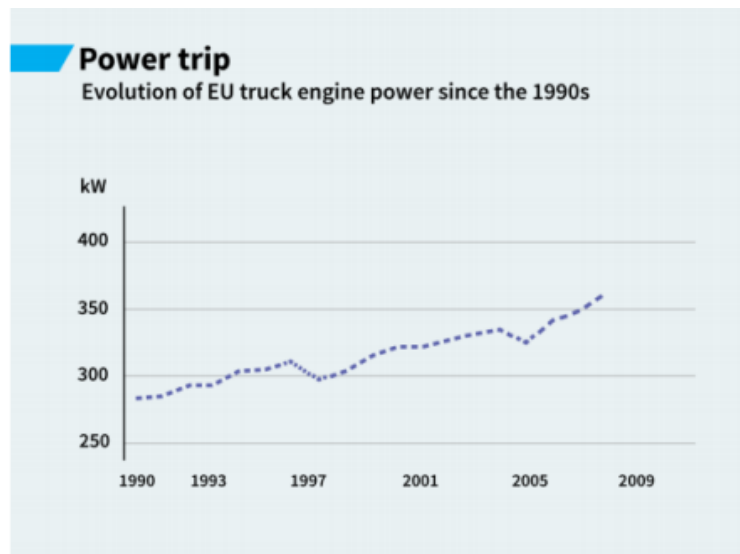

Figure 14: Evolution of EU truck engine power since the 1990s. (Source: transportenvironment.org)

Here we have data about fuel consumption of different truck manufacturers:

Manufacturer	Model	Year	“Part load” fuel consumption (l/100km)	“Overall” fuel consumption (l/100km)
DAF	FT 85.400 295kW, 11600cc	1996	20	32.9
	XF440 FT .400 320kW, 10800cc	2014	20.8	35.6
MAN	19.403 FLS, 294kW, 11967cc	1995	19.9	30.4
	TGX 18.480 353kW, 12419cc	2014	22.7	37.03
Mercedes	1838LS 280kW, 14638cc	1994	24.2	35.8
	1863LS 460kW, 15569cc	2014	22.7	35.8
Scania	R113 MA 400A, 295kW, 11000cc	1994	21.4	34.7
	450 LA 331kW, 12700cc	2014	21.78	37.15
Volvo	FH12/340 250Kw, 12100 cc	1995	23.2	34.7
	FH460 338Kw, 12800 cc	2014	22.79	37.15

Table 2: Fuel consumption for different truck manufacturers (Source: transportenvironment.org)

Different plans for fuel efficiency in trucks have been proposed in the last years. For instance, in the US, they have proposed a fuel efficiency and GHG standard for new trucks. Class 8 sleeper cab tractor trailers (similar to European 40 tone semi-trucks) will be required to improve their fuel economy to 26,7l/100 km. This means an improvement compared with the 38,5l/100km they were required for 2017 as a baseline (even in fact 31,7l/100km were required).

In Europe things have been different, according to a study of German Environment Agency in 2015 a truck in Europe averaged of around 34,5l/100km. However, other independent magazines suggested that actual fuel consumption was higher (around 36-38l/100km). In the last years, fuel efficiency for trucks has been stable and due to the absent in regulation improvements are not expected. Tractor-trailer fuel efficiency is expected to rise in a 0,5% per year until 2030 according to a study assessed by AEA-Ricardo's estimates. European Commission was more optimistic and assumed improvements of 1% per year.

However, doing comparison between American and European trucks is not always certain. This happens because the maximum weight for American trucks is of 36 tons, whereas for European trucks is of 40 tons. Equally, driving profiles are different in the US and Europe. Therefore, the graph it should not be seen as an exact comparison between these two areas but it shows how the trend is. As seen in Figure 15, the US truck efficiency is increasing much faster than in Europe, with an effect that American trucks will be the most efficient in the world at the beginning of the 2020 decade.

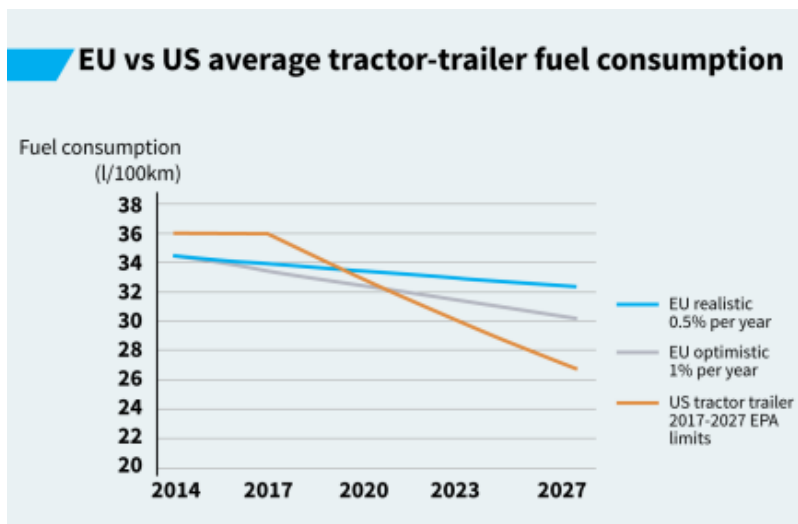

Figure 15: Comparison of EU and US fuel tractor trailer consumption (Source: transportenvironment.org)

## 1.2.9. Regulations for emissions of trucks

### 1.2.9.1. European Emission Standards

European emission standards are referred as Euro1 until 6. Arabic numerals can be used too, but Roman numerals are used when referring to referencing the standards of heavy-duty engines. Another convention is the use of EURO in capitals in order to refer to heavy vehicles.

The introduction of heavy-duty standards was done with the directive 88/77/EEC and was continued by different amendments. In 2005 the standards were consolidated with Directive 05/55/EC. From Euro VI stage on legislation has simplified and directives, which had to be adapted to different national legislations, were replaced by directly applicable regulations.

This is the chronology of standard introduction:

- In 1992 Euro 1 standards were introduced which were followed by Euro II standards in 1996. These standards were applied both in the case of truck engines and urban buses, but in this last case just in a voluntary way.
- In 1999 Directive 1999/96/EC was introduced by the EU, with this directive Euro III standards were elaborated in 2000 and Euro IV/V standards between 2015 and 2018. This rule was of voluntary application and was adapted for “enhanced environmentally friendly vehicles” or EEVs, which have extra low emission limits.
- In 2001 Directive 2001/27/EC was adopted by European Commission. This directive prohibited the emission of “defeat devices” and irrational emission control strategies. These devices decrease the efficiency of the emission control systems.
- In 2005 Directive 2005/55/EC was adopted, it served for introduction of on-board diagnostic (OBD) requirements and for re-stating the limits for Euro IV and V.
- Regulation 595/2009 introduced emission standards for Euro VI.

Euro VI regulations include:

- Emission limits and requirements in the case of off-cycle emissions and in-service conformity service.
- Ammonia ( $NH_3$ ) concentration limits of 10 ppm for CI (WHSC+WHTC) and PI (WHTC) engines.
- Maximum values for  $NO_2$  components of  $NO_x$  emissions.

In the following tables are shown the emission standards for steady-state testing (applicable to diesel engines only, both diesel and positive ignition engines) and transient testing (both diesel and positive ignition vehicles).

EU emission standards for heavy-duty CI (diesel) engines: Steady-state testing								
Stage	Date	Test	CO	HC	NOx	PM	PN	Smoke
			g/kWh					1/kWh
Euro I	1992, ≤ 85 kW	ECE R-49	4.5	1.1	8.0			
	1992, > 85 kW		4.5	1.1	8.0	Euro IV		
Euro II	1996.10		4.0	1.1	7.0	Euro V		
	1998.10		4.0	1.1	7.0	Euro VI		
Euro III	1999.10 EEV only	ESC&ELR	1.5	0.25	2.0	0.02		
	2000.10		2.1	0.66	5.0	0.10		0.15
Euro IV	2005.10		1.5	0.46	3.5	0.02		0.8
Euro V	2008.10		1.5	0.46	2.0	0.02		0.5
Euro VI	2013.01	WHSC	1.5	0.13	0.40	0.01	$8.0 \cdot 10^{11}$	0.5

Table 3: EU emission standards for heavy vehicles (Steady-state testing)

EU emission standards for heavy-duty CI (diesel) engines: Transient testing								
Stage	Date	Test	CO	NMHC	CH4	NOx	PM	PN
			g/kWh					1/kWh
Euro III	1999.10 EEV only	ETC	3.0	0.40	0.65	2.0	0.02	
	2010.10		5.45	0.78	1.6	5.0	0.16	
Euro IV	2005.10		4.0	0.55	1.1	3.5	0.03	
Euro V	2008.10		4.0	0.55	1.1	2.0	0.03	
Euro VI	2013.01	WHTC	4.0	0.16	0.5	0.46	0.01	$6.0 \cdot 10^{11e}$

Table 4: EU emission standards for heavy vehicles (Transient testing)

### 1.2.9.2. Post Euro 6/VI regulations

Four years have passed from the Dieselgate scandal, in which the distrust for European emission was increased. This is scandal exposed the failure to curb toxic air pollution from cars. The future post euro-6/vi normative, which informally is called euro-7/vii, is an opportunity to eradicate pollution, increase confidence and leadership and create the scenario in order to achieve the goal of net-zero greenhouse effect emissions by 2050. Covid-19 global health crisis which currently affects Europe makes health, safety and job security of workers the main priority for regulators and makes objectives of post-Euro 6/VI more important than ever before. Two factors increase this danger: By the one hand experts in public health estimate that polluted air makes inhabitants more prone to viruses and by the other hand the amount of infectious diseases and viruses will increase too with climate change.

EURO-6/VI standards have reduced the emissions from new cars but with a limited progress because combustion engine vehicles are still not clean in all driving conditions and pollutants. As a result, future regulations should set the following priorities:



- Setting EU emission limits lower than anywhere else and defining a clear roadmap to zero. For heavy vehicles this can be achieved by using off the shelf technology, which can reduce NO<sub>x</sub> emissions to just 10% of current limit (460 mg/kWh). Chinese and US limits will be more restrictive than the Europeans in 2023 and 2025 respectively, so the EU needs to actuate and apply limits to every internal combustion engine (including compressed and liquefied natural gas), port-fuel injection petrol engines and advanced or synthetic fuels and hybrids.
- Regulating and taking in account in account all the pollutants which affect public health and environment. Includes regulating tiny particles (which are included within this category which can penetrate the vehicle and are emitted in big quantities from the tailpipe of all vehicles), ammonia, nitrogen dioxide (*NO<sub>2</sub>*) (dangerous fraction of nitrogen oxide (*NO<sub>x</sub>*) need to be regulated through a different limit), more stringent limits to greenhouse gases such as methane and nitrous oxides, dangerous chemicals (formaldehyde, acetaldehyde and non-methane organic gases ,NMOG) and a better measurement for volatile and semi-volatile particles.
- Doing tests and certificates to vehicles in order to determine that emission limits can be applied in any kind of driving conditions Different temperatures and altitudes should be taken in account. For trucks and heavy vehicles low-load, low speed test cycle and *NO<sub>x</sub>* idling limits should be introduced.
- Emission limits should be met in the whole lifetime of the vehicle and not just in their first operation years. Nowadays the required limits are just of 5 years/160000km for light duty vehicles and 7 years/700000km for heavy duty vehicles.

### **1.3. Intermodality of transportation**

Nowadays there is a trend for the increase of cooperation between different transportation modes including road, rail, water and air which lead to an increase in volume of intermodal transportation. This cooperation and coordination of transportation mode has as an aim to realize more economic and faster transport chains. It allows eliminating the different disadvantages that the modes have while at the same time creating synergies between them.

One big aim of intermodal transportation is the reduction of volume of road transportation. It is important to reduce it due to the big number of externalities it generates (environmental pollution, traffic jams and accidents), so these externalities can be eliminated. However, even if these cooperation efforts are being done the predictions show that the volume of road transport will increase in the future and it will be continue being the main transportation mode.

There are three main organizational structures in transport task fulfilment in terms of location of stations are line structure, ring structure and star structure. Stations can be

either the sites of companies, stations where products are loaded in to be transported and stations where products are loaded out to be transported. Stations can be linked in several ways and create more complex networks depending on their location and the freight demand. Combined networks can be created resulting from combination of line, ring and star networks which include line-star-networks, star-cluster-networks and ring-line-networks.

In road freight, the most used alternatives are ring structures and star structures. In international road freight transportation, the most typical structure is the ring one (which is called round trips).

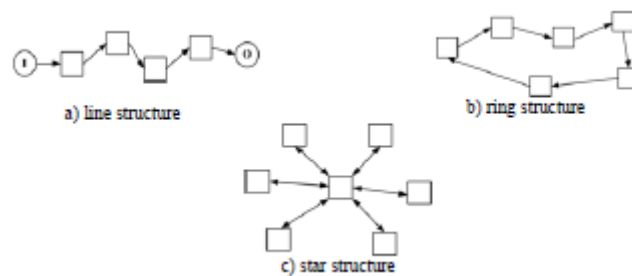

Figure 16: Different intermodal structures

## 2. ROAD TRANSPORTATION IN WESTERN PYRENEES: N121A VS A15

This project studies the route that connects French and Spanish border in Western Pyrenees coast via road. For the Spanish economy this route is very important, as it is one of the two main entries to continental Europe. Both of this main entries are located in the coast as the inland is a mountainous region. The other main entry via road is located in eastern coast in Catalonia.

In a globalized world where international commerce is becoming more and more important it is crucial to know which road alternatives are the most accurate ones for different border crossing points and in this case the one between Irún and Hendaye in Western Pyrenees coming from Pamplona.

### 2.1. Definition of the problem

Two different road alternatives will be compared in order to determine which is the most efficient for freight transportation in terms of environmental impact. Environmental impact can be decomposed in different emissions but in quantity the greatest one is  $CO_2$ .

The two possible roads are the ones communicating Pamplona and Irun through the highway A-15 and the national road N-121-A. The use of these both roads has generated a big social debate over the last few years. Especially because N-121-A road, which is the shortest route in order to do this journey and does not have any toll, is a road with a big accident rate; in a great amount because of the big heavy truck traffic. Both routes start in different point in the metropolitan area of Pamplona, the N121-A route in km 6,85 of this road, in the intersection with PA-30 road between Arre and Oricain passing Ezkaba tunnel. A-15 route starts when taking AP-15 from Berriozar (in kilometric point 102,54). Both routes end in the Spanish/French border point in Irún/Hendaia.

## 2.2. Roads Compared in this Project

### 2.2.1. A-15 Highway

A-15 highway is a Spanish highway which starts in the A2 highway in Medinaceli (Soria province) and finishes in San Sebastian (Gipuzkoa). It is divided in 4 sections: Autovía de Navarra (between Medinaceli and Tudela), ronda de Pamplona Oeste (which goes through the capital city of Navarre), Autovía de Leizaran (between Irurzun and Andoain) and Autovía de Urumea (between Andoain and San Sebastián).



Figure 17: A-15 highway

The section of this highway concerning this study is the one corresponding to Leizarán. It starts at kilometric point 112,15 of AP-15 motorway in Irurtzun (Navarre) 20 km far away from Pamplona and finishes in Andoain (Gipuzkoa), in the connection 445 with A-1 highway. Then, the A-1 highway connects it with Irún and French border. It has 41km length and was built between 1989 and 1995. Allows communication between Pamplona and San Sebastian in 50 minutes. As it has a nature of mountain highway accidents are quite common, in part due to difficult driving conditions as fog, rain or snow, very frequent in this area of Iberian Peninsula. It has been criticized because it goes through a very big height, which results in slow traffic, bigger consumption of fuel and bigger danger for trucks.

As appears in “III Plan de Carreteras de Navarra 2010-2018”, the latest document available for the development and management of the Navarre road network (the one for 2019-2027 is still in development), in 2007 the average traffic in different stations of this highway was of 20000 vehicles per day. In Pamplona ring road section higher peaks were achieved of 40000 vehicles per day. After passing this ring road section of Ronda de Pamplona the intensity decreases in the AP-15 until 25000-30000 vehicles per day until the fork in Irurtzun of A-10 and A-15 highways. According to data from “Plan de Aforos de Tráfico 2018” by 2018 in Pamplona road ring section there was a maximum intensity of more than 50000 vehicles per day in the highest traffic point. In the border point between Navarre and Gipuzkoa the amount of vehicles per day was of more than 15000 vehicles per day.

Even if the main road crossed in this alternative is A15 there are other roads in which this route goes in Gipuzkoa province:

#### A-1 Highway:

This highway starts in Madrid and finishes in Irun, being one of the main north-south arteries in Spain and also one of the country's busiest highways. The route goes only a few kilometres close to Andoain (Gipuzkoa) across the A-1 highway, also called *Autovía del Norte* (northern highway). Then some other few kilometres between Astigarraga and Erreterria through its toll alternative AP-1.

From Erreterria on the highway continuation in Irun direction becomes the toll motorway AP-8 (an alternative to Irun without toll would imply taking GI-11, GI-20 and GI-636 (in this order) Gipuzkoan regional roads.



Figure 18: N-1 highway

#### AP-8 Motorway:

AP-8, also known as *Autopista del Cantábico*, is a motorway connecting French border in Irun with A-8 highway in Bilbao. A-8 is a 468 km long highway along the Cantabrian sea coast until Baamonde (Lugo). AP-8 is a toll road which passes Basque provinces of Gipuzkoa and Bizkaia. Its part concerning this route is the stretch between San-Sebastian and Irun.



Figure 19: AP-8 highway

### **2.2.2. N-121-A National Road**

N-121-A also known as Pamplona-Behobia road is a two-lane expressway connecting Pamplona with French border, through the border passes of Dantxarinea and Behobia. It is the main axis of communication of northern Community of Navarre, having a length of 76,1 km. It is also an alternative towards motorways with toll for itineraries between Madrid and Western Europe and main road communication between Navarre and Labourd region in French Basque Country.

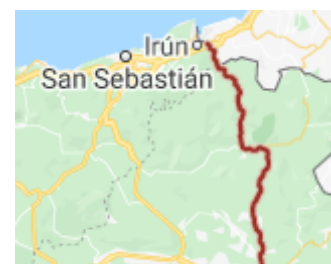

Figure 20: N121-A National Road

This road has recently been converted into a two-lane expressway in the decade of 2000s. For this mission, several viaducts and tunnels were constructed (the most important one the tunnel of Belate which is the seventh longest in Iberian Peninsula.) Is very frequented by truck drivers, which makes it a very frequented road.

Due to the orography it has been gone for adding third lanes. With these lanes, capacity increased by allowing passing cars in slopes. Nevertheless, this road has had a moderate increase in the last years of around 4% in most of its sections. From 7.831 veh./day in 2000 to 10.562 veh./day in 2007 in the section with the biggest traffic.

In the last years, this road has had the greatest concentration of accidents in the Community of Navarre. (31 deaths from 2010 to 2020 January and 125 accidents per year as average). As a result, some jobs are being recently done in order to have a double continuous line in the whole road (passing only will be allowed in sections with double lane in current direction).

### **2.2.3. Accident rates in N-121-A and 2+1 conversion**

As said before, N-121-A is not a road only generating a big debate within transporters and operators but also in the whole society. There is a big polemic in the last few years which has not finish even of the construction of double lanes or the Belate tunnel in order to improve the security. However, the road continues being very dangerous in part because of the big amount of trucks that transit through this road. More than 3000 trucks travel the road every day, following a European route which makes the function of connecting the Iberian Peninsula with French border and rest of European countries. Truck drivers who come from the centre, the south and the south-east prefer this road in order to pass the border because it avoids the tolls of the alternative motorways that serve as an alternative route.

Main source of accidents in this road are caused by frontal collisions between vehicles when overtaking in a prohibited area. The most dangerous sector of the road is the one between Bera and Enderlatsa, according to Foral Police of Navarre since 2010 this segment has had 33 accidents per kilometre and 163 accidents in total.

This road passes through many small towns too in the valleys it crosses, this causes a big amount of intersections. Moreover, it causes the interaction in the road between different kind of vehicles (small private cars vs big trucks) and vehicles following different routes (long international ones vs short regional everyday transfers).

In 2017 the government of Navarre allowed an investment of 530.000 euros in order to convert N-121-A in a so called 2+1 road. This means a road with two directions of traffic and three available lanes. One of the three lanes is located in the centre and in regular intervals it is used for overtaking in each one of the ways. These measures are being taken in 63 kilometres of the road and are included within a set of measures to be taken in order to improve the functionality and traffic safety of the road.

In order to avoid this problematic several measures are being taken by regional government:

- **2+1 Platform:**

It is the main measure included within this project. Aims to convert N-121-A road in its whole distance in a 2+1 road. It avoids all the overtakings in which the opposite direction is invaded and also avoids turns to the left in intersections. From an environmental point of view, the impact is not relevant and enhances the barrier effect of the road. From a socio-economic point of view it offers a high cost/efficiency ratio, maintains the idiosyncrasy of the area and there is not a calling effect bringing more traffic to the infrastructure.

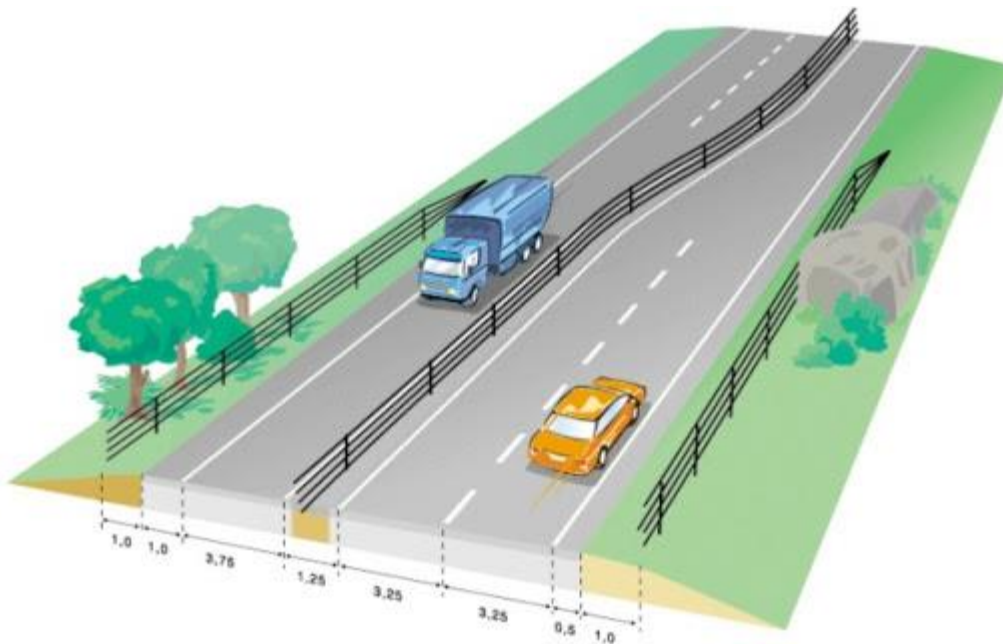

Figure 21: 2+1 road

- **Modification of 19 intersections:**

Improvements are being taken in order to modify 19 existing intersections to get a higher safety in different movements, especially in turns to the left. Six of these intersections will have a common design with an external roundabout allowing a change of direction, four intersections will be converted into roundabouts and the rest of them will have a shape of T.

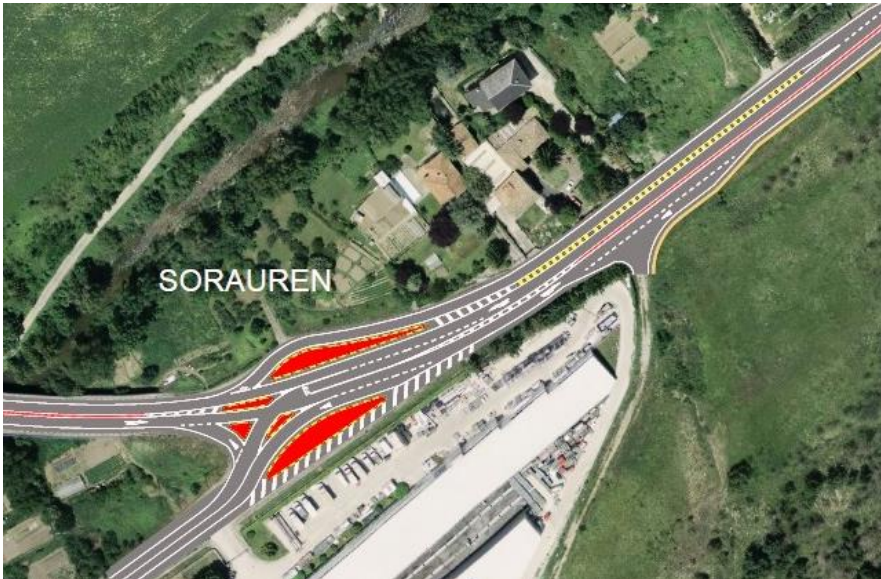

Figure 22: Improved intersection in T

- **Homogenization of the road speed limits:**

Before there were dissimilarities between the maximum speeds allowed and in segments of similar characteristics there was not the same limitation. With these measures the maximum speed all along the road will be of 90 km/h, in intersections it will be of 70 km/h and in urban areas the speed will be of 50 km/h.

- **Re-ordination of the accesses:**

N-121-A road used to have many accesses from rustic and urban isolated smallholdings, industrial units, petrol stations or restaurants. The aim analysing the whole of them in order that these accesses affect in the least possible way to traffic. Some of them will be closed while others will be redesigned in order to obtain a greater amount of security and comfort in the driving.

#### **2.2.4. Viability analysis of proposal for improvement of N-121-A into a 2+1 road**

In the case of N-121-A, the problem related to it is the big amount of heavy vehicles that causes a high amount of accidents. As a result and as mentioned before, the government of Navarre has decided to convert the road in a 2+1 road. These type of roads have an accident rate similar to motorways. Apart from this, the government of Navarre has decided to implement tolls for heavy trucks as a dissuasive measure. However, as with this study both in environmental and economic terms has shown to be a more accurate alternative this measure will not be taken in account in this study.

In fact, if with the implementation of 2+1 lane roads the security of N-121-A could improve without worsening its positive aspects (lower fuel consumption because of smaller distance and lower ascent grades) this would be the best solution. For this reason, in the next section of the Project, viability of investments to implement 2+1



lanes will be invested. Because if this Project is viable, N-121-A will continue being the most accurate road from an environmental and economic point of view and will have similar values to A-15 in terms of security (accidents will be reduced in a great amount).

The cost of this investment would be of an amount of 70 million €-s plus 100 million €-s with the purpose of splitting Belate and Almandoz. The price of building a motorway in the same route as an alternative would have a cost of 1000 million €, a much higher cost. (Source: Noticias de Navarra)

In half of the route (35 out of 70 kilometres) the road will include a separation barrier, with a height of 0,6 metres and a distance between posts of 4 metres, which will be installed in a central reservation of 2 metres of width. The aim of these barriers is to avoid at 100% the front-side shocks.



Figure 23: Accident in N-121-A of January 2020 in which two young boys of 19 and 21 years old died

#### Accident Statistics in N-121-A:

- Since 2010 31 people have died in accidents in N-121-A.
- Since 2010 69 people have resulted critically wounded and 217 slightly injured.
- From 2017 to 2019 according to *Área de Tráfico y Seguridad Vial de la Policía Foral* there were in total 345 accidents in this road. (13 people death)
- As a result, the average number of accidents per year is of around 115, the average number of death people is 3.1 per year and in the case of wounded people per year 6.9 heavily and 21.7 slightly.

<b>N-121-A accident statistics</b>	
Deaths per year	3.1
Heavily wounded per year	6.9
Slightly wounded per year	21.7
Accidents per year	115

Table 5: N-121-A accident statistics

#### 2.2.4.1. Economic valuation of accidents

For giving economic valuations to the cost of traffic accidents, as this is a highly costly task by itself. As a result, an inform elaborated in 2019 by RACE (*Real Automóvil Club de España*) called *Informe sobre Seguridad Vial Laboral en España*, was being used for these economic valuation. However even if this source is the most recent one for giving monetary values to car accidents, these values are estimations are based in traffic work accidents and no in overall traffic accidents.

This is the reason why finally the data is taken from a study elaborated in 2011 by DGT (Dirección General de Tráfico) in cooperation with University of Murcia. Costs associated to traffic accidents were estimated with victims using the method of willingness to pay (WTP). Therefore, a death victim would suppose a cost of 1.4 million of € (including inside these costs direct and indirect costs as medical, administrative... and the price associated to the bonus that society would be keen to pay in order to reduce for dying in a car accident, known as the value of a statistic life). Following the same methodology, costs associated to a hospitalized wounded and no hospitalized ones have been calculated in 219,000 € and 6,100 € respectively.

When assessing the economic costs of accidents, different aspects need to be taken in account including administrative costs, material costs and costs associated to victims (including medical costs, productivity losses and human costs).

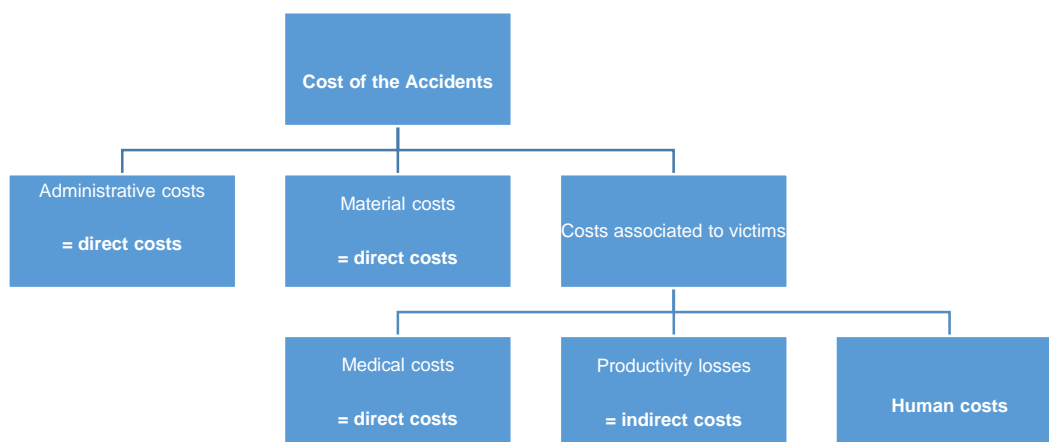

Figure 24: Types of costs of accidents

As data could not be found in the literature according to accidents without injuries a supposition will be made that the costs of them are of 3050€ (there is data according to DGT that in 2004 material costs supposed 44% of total costs of accidents, so in this case the cost could be approximated as 50% the cost of an accident with injured victims).

As the medium occupation per private vehicle was of 1.7 (Barcelona 2013, there was no data in the literature for Navarre or more recent years), the value of 3050€ is multiplied by 1.7 so all the occupants are taken in account as these values are per victim and not per accident (there would be also accidents of collisions with many cars implied but this

would make the estimations more complicated, so we assume that all the accidents were just of a single car for simplicity).

According to this source the economic valuation of traffic accidents was the following one:

<b>Economic valuation of traffic accidents</b>	
Accident without victims	$3,050\text{€}/\text{occupant} * 1.7\text{occupant}/\text{car} = 5,185\text{€}$
Minor victim	6,100€
Grave victim	219,800€
Deaths in accidents	1,400,000€

Table 6: Economic valuation of traffic accidents

As a result, with these estimations, the overall cost of N-121-A just because of the victims in traffic accidents is the following one:

<b>Total cost of N-121-A because of traffic accidents</b>	
Cost because of accidents	$5,185\text{€}/\text{accident} * 115\text{accidents}/\text{year} = 596,275\text{€}$
Cost because of minor victim	$6,100\text{€}/\text{victim} * 21.7\text{victim}/\text{year} = 132,370\text{€}$
Cost because of grave victim	$219,800\text{€}/\text{victim} * 6.9\text{victim}/\text{year} = 1,516,620\text{€}$
Cost because of deaths in accidents	$1,400,000\text{€}/\text{victim} * 3.1\text{victim}/\text{year} = 4,340,000\text{€}$
<b>Total Cost</b>	<b>6,585,265€</b>

Table 7: Total cost of N-121-A because of traffic accidents

Supposing that the implementation of a 2+1 lane road would reduce the amount of victims in a 50% (something realist because nowadays the accident rate in N-121-A is very high because the high presence of heavy trucks, an extra lane could reduce the collisions happening during overtakings in a great amount). Also taking in account that 9% of death victims during the last 10 years in Navarre have dead in this road, which is a very big amount taking in consideration that is just a single road.

There is evidence in the literature that the implementation of 2+1 lanes can save a big percentage in accidents. According to *Bergh et al* it can reduce the number of accidents in an amount between 80 and 90 percent.

*“There were a lot of critical views on the proposal concerning among other issues different aspects of level-of-service. The first road was opened in the autumn 1998. Today there are more than 2 700 km 2+1 median barrier roads in Sweden covering some 14 % of the total Swedish state mileage with a 2+1-roads Recent Swedish Capacity and Level-of-Service Experience T. Bergh et al. 332 history of impressive safety success, some 80 to 90 % fatality reduction, and also mainly positive level of-service findings. The fatality reduction without barrier according to Swedish experience is minor.”*

If so, the reduction in cost caused because of reduction of victims would be the following one:

<b>Reduction in cost per year because decrease of accidents</b>
6,585,265€*0.5= 3,292,632.5€

*Table 8:Reduction in cost per year because decrease of accidents*

This is not the only saving the implementation of 2+1 lanes would be introduced as it could increase efficiency and reduce traffic jams causing a reduction of driving times. However, these savings are very difficult to quantify so in this study there is only an insight in the cost saved by the reduction of accidents (which is the main problem related to N-121-A road). In order to quantify the profitability of N-121-A from the perspective of the savings due to reduction of accidents and the economic cost they imply internal rate of return (IRR) will be calculated.

### **2.2.5. Internal Rate of Return Calculation**

The internal rate of return (IRR) is a tool used in financial analysis in order to estimate the profitability of potential investments. It is a measure for an investment which refers to its future rate of return. The internal rate of return is a measure that makes net present value (NPV) of all cash flows equal to zero in a discounted cash flow analysis.

The formula used for its calculation is the following one:

$$0 = NPV = \sum_{t=1}^T \frac{c_t}{(1 + IRR)^t} - c_0 \quad (3)$$

Where:

$c_t$ = Net cash inflow during period t

$c_0$ = Total initial investment costs

IRR= The internal rate of return

t= The number of time periods

For calculating the IRR, the NPV needs to be set equal to zero and the discount rate solved, which is the IRR. However, due to the nature of the formula the IRR is not easy to calculate analytically, so trial and error or programmed software need to be used in order to solve it. In general, the higher is the IRR the most favourable is the investment.

The internal rate of return will be calculated for this investment for a time period of the following 25 years with Gabilos Software calculator tool, as for so many years is not such a simple calculation. The result achieved is that with the investment of 70 million euros in order to implement the 2+1 lanes in N-121-A the expected IRR is 1.31%, if this value is higher than the discount rate k the investment should be accepted.

Collections and payments generated by the investment			
YEAR	COLLECTION	PAYMENT	CASH FLOW
0			-70.000.000,00
1	3.300.000,0	0,0	3.300.000,00
2	3.300.000,0	0,0	3.300.000,00
3	3.300.000,0	0,0	3.300.000,00
4	3.300.000,0	0,0	3.300.000,00
5	3.300.000,0	0,0	3.300.000,00
6	3.300.000,0	0,0	3.300.000,00
7	3.300.000,0	0,0	3.300.000,00
8	3.300.000,0	0,0	3.300.000,00
9	3.300.000,0	0,0	3.300.000,00
10	3.300.000,0	0,0	3.300.000,00
11	3.300.000,0	0,0	3.300.000,00
12	3.300.000,0	0,0	3.300.000,00
13	3.300.000,0	0,0	3.300.000,00
14	3.300.000,0	0,0	3.300.000,00
15	3.300.000,0	0,0	3.300.000,00
16	3.300.000,0	0,0	3.300.000,00
17	3.300.000,0	0,0	3.300.000,00
18	3.300.000,0	0,0	3.300.000,00
19	3.300.000,0	0,0	3.300.000,00
20	3.300.000,0	0,0	3.300.000,00
21	3.300.000,0	0,0	3.300.000,00
22	3.300.000,0	0,0	3.300.000,00
23	3.300.000,0	0,0	3.300.000,00
24	3.300.000,0	0,0	3.300.000,00
25	3.300.000,0	0,0	3.300.000,00

First investment	70.000.000,00
I.R.R.	1,31%

Figure 25: Calculation of IRR with Gabilos software calculator tool

### 2.3. Transportation at the Pyrenees

This project studies transportation in two roads which are considered to be in the Pyrenean transportation axis. There are 27 connections between France and Spain across the Pyrenees, of different kinds, one of which connects both countries crossing Andorra. Main roads for this connection are coastal motorways (AP-7/A9 in Mediterranean coast and AP-8/A63 in Atlantic Coast), which have 40.6% of inter-border traffic (OTP,2019). In the case of heavy transportation, the percentage in coastal motorways is much higher (with 92% of global inter-border heavy transport in 2015, OTP 2018). Other roads as Basque bridges (from Irún to Béhobie and Hendaye) and inland roads, had only 3% and 5% of heavy traffic, respectively.

As we can see in the image, in 2016 the main transportation mode between France and Spain was road transportation (54.8 million of tons, with a huge difference to the second mode which was maritime with 11.4).

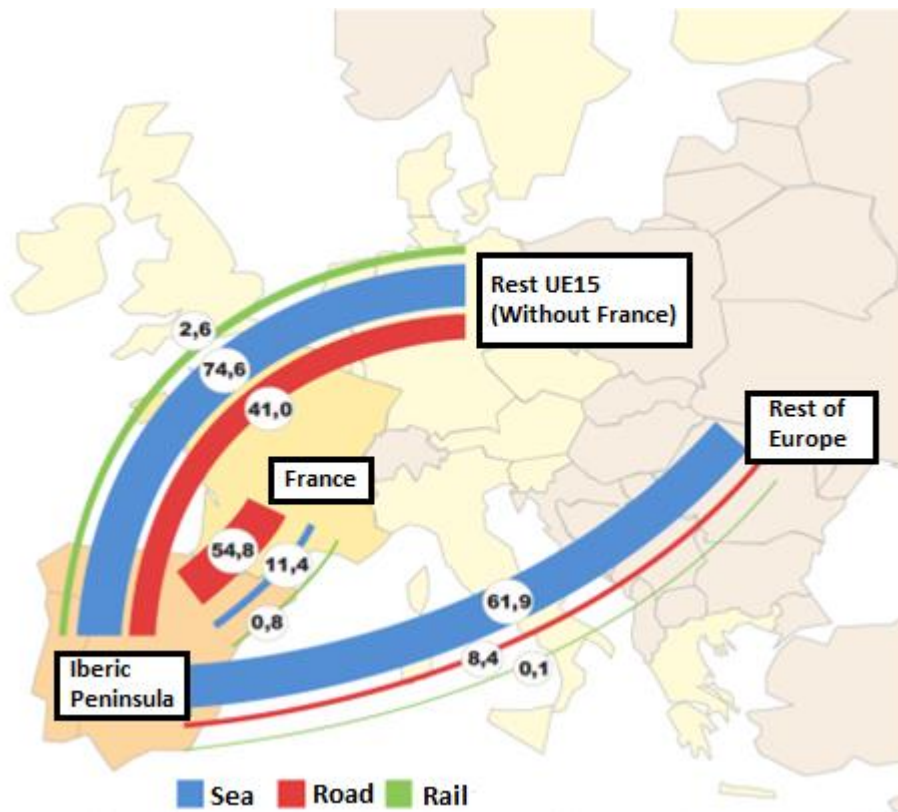

Figure 26: Traffic flows of different modes from Iberian peninsula to Europe (Source: Observatorio hispano-francés de Tráfico en los Pirineos, 2019) (Translated from Spanish)

In order to have a realistic model, we have to search in the literature the most common loads transported in the roads studied and also the kind of vehicles used. Regarding A-15 highway we have to check the data of motorway AP-8/A63 in south north direction, as it is the continuation of A15 highway in northern direction in the way to France.

*“Observatorio hispano-francés de Tráfico en los Pirineos”*, which is an observatory of traffic in Spanish-French border, gives information about the average load transported by freight transporters in main border roads. For AP-8 it was an average of 15.1 tone/heavy vehicle regarding a survey by them in 2010. For Basque bridges (ones from Irún to Béhobie and Hendaye which are usual border passes if you come from N121A) the average load was 9.3 tons/vehicle. For the rest of main inland roads, the average was of 14.2 tone/heavy vehicles.

<b>Roads</b>	<b>Average load (t/ P.V.)</b>	<b>Source</b>
Motorway AP-8/ A63 North-South	14.1	Transit survey 2010 in motorways
Motorway AP-8/ A63 South-North	15.1	Transit survey 2010 in motorways
AP-7 / A9 North-South	12.3	Transit survey 2010 in motorways
AP-7 / A9 South-North	15.5	Transit survey 2010 in motorways
R.D. 912 and R.N 10	9.3	Transit survey 2010 in motorways in Basque bridges
Other R.N.	14.2	Transit survey 2010 in motorways in inland crossing points





Regarding the vehicles crossing the border (because for instance traffic to AP-8 comes not only from A-15 but also from A-1 and AP-1) the average was of 8960 in A-8 in both directions, 620 for N-1 Irun Béhobie N-1 and 420 for Irun-Hendaye in GI-636. As we can see in the data from 2003 to 2015, AP8/A63 has had an increase in the total number of heavy vehicles whereas in Basque bridges the tendency has been stable and even a bit declining.

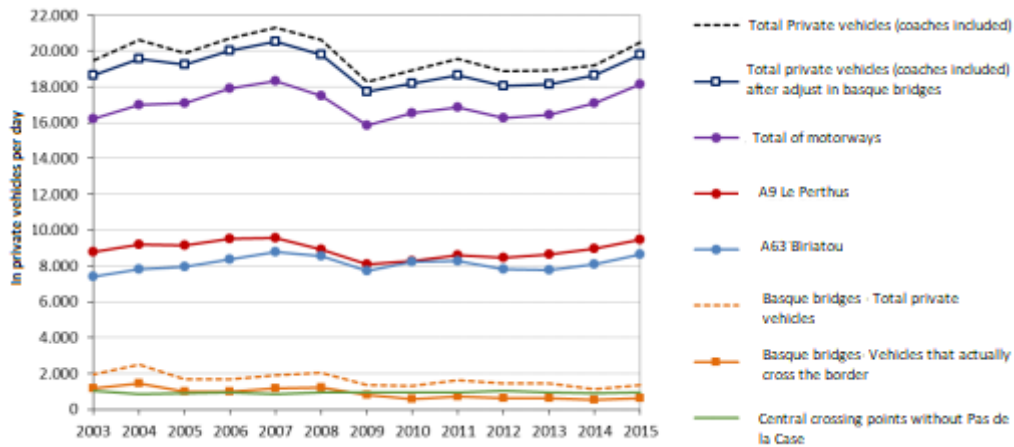

Figure 28: Number of heavy vehicles per day in main Pyrenean roads (Source: Observatorio hispano-francés de Tráfico en los Pirineos, 2018) (Translated from Spanish)

## 2.4. Routes definition

### 2.4.1. Geographic Information System

Geographic information System (GIS), is a system able to capture, store, manipulate, analyse and present spatial or geographic data related to positions on Earth's surface. It can use whichever information including location, which can be expressed in different ways such as latitude and longitude, address or ZIP code. It can have information of many kinds: data about people (such as population, income or education level), about landscapes (such as location of streams, different kinds of vegetation and different of soil). It can also have information about sites of factories, farms, schools, storm drains and electric power drains.

It can ease decisions related to locations subject to different criteria and how they affect towards each other as for example levels of pollution and sensitive to pollution areas. With this map we could determine for example which water supplies are at risk. Other examples of GIS applications could be: Choosing new store locations, reporting power outages, analysing crime patterns, routing in car navigation and water forecast and prediction.

An example of the necessity for the following systems would be the following one:

If you visualize latitude and longitude components of some locations from a spread is very difficult to make an idea of their location.

City	Latitude	Longitude
Seattle	47.5°	-122.3°
New York	40.7°	-73.9°
Miami	25.8°	-80.2°
Los Angeles	33.9°	-118.2°

Table 9: Example of simplification of data because of use of a GIS

But when these positions are added into a map everything is much clearer:



Figure 29: Example of simplification of data because of use of a GIS 2

Maps make geographical information easier and allow having a geographical context. This context can be used for calculating how different points are far from each other, check if points follow some specific trends and find optimal routes between cities.

This are the components of a GIS system:

- **Data:** It is stored in location data as thematic layers. All the data sets have an attribute table storing information about the feature. Two different kinds are vectors and rasters.
- **Hardware:** Is what runs GIS software (can be a powerful server, a mobile phone or a personal GIS workstation).
- **Software:** ArcGIS and QGIS are the leader programs in this industry. This software is specialized in using maths in maps to perform spatial analysis.

The community of Navarre, where this study is held, has its own GIS information system called SITNA (Sistema de Información Territorial de Navarra). It is an integration of all the initiatives related with GIS systems in the region.

Some of its features are:

- Having an image related to corporative image of Navarre Community.
- Having a full page map viewer.
- Map viewer compatible with different browsers.
- Availability of different information layers.
- Free download of a SIG tool and data about Navarre.
- Information search.
- Variety of contents and sections.
- Different languages (Spanish, Basque and English)

#### 2.4.1.1. SITNA

SITNA is the offer by the Government of Navarre for those requesting information about this territory. From 2008 on incorporates information that already appeared in the latest version of SITNA tailoring it to the current style of the institutional website.

One of the main aims of this geoportal is achieving a higher integration of the different initiatives related to the Geographical Informative System of Navarre. With this aim in mind, by the end of 2009 a new version of IDENA (Navarre spatial data infrastructure) was presented strengthening the integration of its contents in the geoportal while preserving characteristics and requirements of an SDI.

It has he following characteristics:

- Reflecting corporate image of Portal of Navarre.
- Showing a full screen map viewer in the Internet.
- Compatibility of the map viewer with the main browsers as Chrome, Edge, Firefox and Safari.
- Offering a big variety of layers available.

- The tool SITNAMAP which allows free download of a GIS tool and data on Navarre.
- Option to search for information.
- Offering a big variety of contents and sections including metadata, glossary, FAQs...
- Availability in three languages as Spanish, Basque and English.



Figure 30: SITNA Geoportal

#### 2.4.1.2. ArcGIS

ArcGIS is a geographical information system (GIS) which is valid for working from maps. It is maintained by the Environmental Systems Research Institute (Esri). It was created in 1997, when Esri decided to create a single software architecture. Since then, 26 versions have been developed being the 10.8.

Its main functions are the creation and use of maps, the compilation of geographic data, analysis of mapped information, sharing and discovery of geographical information, map and geographic information use in a range of applications and management of geographic information in a database.

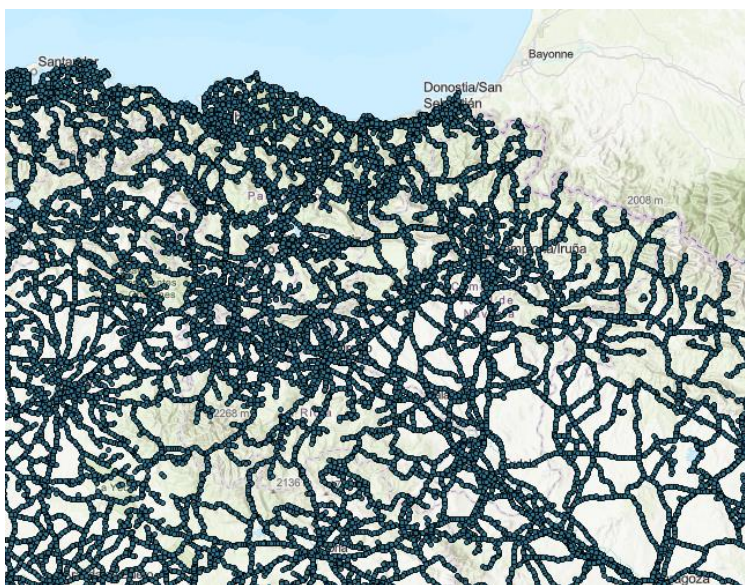

Figure 31: Kilometric points of the road from ArcGIS software

It has a system which provides infrastructure for the creation of maps and geographic information, which is available throughout and organization, across a community and in the web. It offers different Windows desktop software:

- ArcReader: Allows one view and query maps created with other ArcGIS products. It is included with any of ArcGIS products and also available free for download.
- ArcGIS Desktop: It is made of 4 main applications. ArcMap (editing spatial data in two dimensions and creating two-dimensional maps), ArcScene (viewing and editing three-dimensional spatial data), ArcGlobe (displaying large 3D datasets) and ArcCatalog (GIS management and manipulation).
- ArcGIS Pro: It is a new integrated GIS application which includes artificial intelligence (AI) as well as 2D and 3D for cartography and visualization.
- ArcGIS online: It is a web application which allows sharing and searching for geographic information and content published by Esri or ArcGIS users.

## **2.5. Effect of gradients in roads**

### **2.5.1. Passenger cars**

For passenger vehicles, even if the practice of vehicle operators changes over the gradients, there is a general agreement that nearly all passenger vehicles can easily deal with gradients of 4 or 5 percent without changes in the usual speed they have. The exception are vehicles which have a high relation between weight and power, including some compact and semi-compact vehicles.

Studies show that in conditions of low traffic congestion ascent slopes of 3% grade, comparing to a horizontal one, only has a light effect in speed of passenger cars. For steeper gradients speeds decrease progressively with an increase in ascending slopes. In long and soft gradient drivers tend to travel a bit quicker in descent than in ascent gradients, but depends also in local conditions.

### **2.5.2. Road freight vehicles**

The effect of gradients in the speed of trucks is much higher than in the case of passenger cars. In flat roads the average speed of trucks is much more homogeneous to passenger mostly of the length and steepness of the road and in the weight/power relationship. Some other variables which affect to the average speed in the whole length of the grade are speed of entry, resistance of wind and the ability of the operator (last two only causing some minor variations).

Gradient is very important in the design of roads because of the limitation of speed they cause in trucks. As a result, there are some critical lengths and percentages for gradients in order to be safe. This safety is achieved if the difference in speed of average traffic and heavy vehicles (which are obviously slower due to its weight) is lower than 15 km/h. If this difference is bigger the situation would get dangerous because of collisions. In the Figure 32 it can be seen, in order to have this standard difference of 15 km/h for a representative truck of 180 kg/kW, which are the lengths and percentages.

As it can be shown in figure 32 it can be obtained the speed at which a truck speed will become constant in a grade and also what will be its speed after a certain distance.

The weight-power relationship is very important in order to estimate the journey time of trucks in gradients and in consequence their speed. It is supposed that vehicles with the same weight-power relationship have similar operation characteristics. The weight-power relationship is often given in terms of gross weight and net power. It has been discovered that trucks with a net power of 180 kg/Kw (134 kg/HP) have reasonable operation characteristics from a road user perspective (some evidence show that in car industry this value would be a minimum optimum for the design of commercial vehicles). Weight-power relationships have been improved over the years, the data show that this relationship for a vehicle of 18000 kg net weight improved from 220 kg/kW in

1949 to 80 kg/kW in 1985. As this relation decreases this means bigger power and better capacity to ascent. There is trend for having bigger and heavier trucks of until three trailers, which are allowed in certain roads of USA. However, studies show that if the number of axles increases it also does the weight-power relationship.

In terms of maximum gradients of design, for roads for a guideline speed of 110 km/h the maximum grade should be of 5% whereas for roads with a guideline speed of 50 km/h they are in a range of 7%-12%.

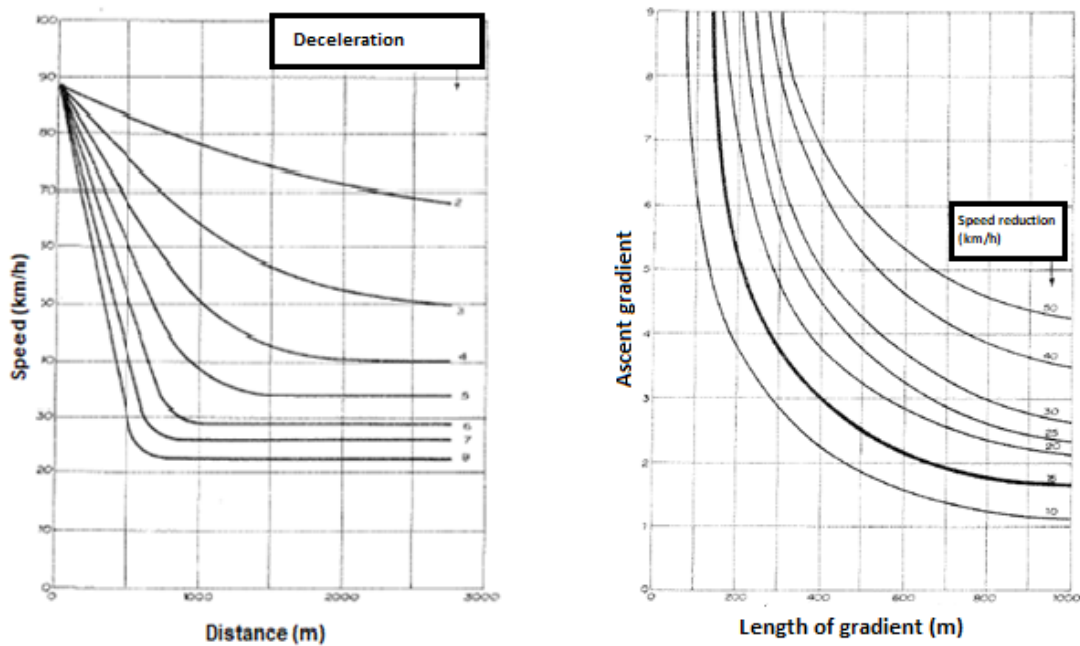

Figure 32: Decelerations of heavy trucks in gradients (Source: Aashto, Translated from Spanish)

## 3. ECONOMIC COSTS

When assessing economic costs of freight transportation activities both external and private costs need to be taken in account (as explained in 1.1.1 apart). The sum of both costs are the social costs. In order to estimate them for these routes different methodologies will be taken in account for each type of costs. These methodologies along with a detailed explanation of each type of cost will be explained further in this chapter.

### 3.1. Private operating costs

Private costs are the costs which individuals, firms or communities have directly to pay when releasing an economic activity (the buyer pays to the seller). They can be also described as the costs internal to the firm's production function.

This kind of costs include labour, material, machinery and anything else that the individual or firm pays for. Private costs do not take in account the harm or negative effects caused as a result of the production.

#### 3.1.1. Calculation of private operating costs

In order to calculate private operating costs of both routes ACOTRAM programme has been used. ACOTRAM is an informatic tool that helps with the calculation of operational costs of road freight transportation vehicles. Moreover, through this program direct costs can be consulted for different vehicles studied in "Observatorio de Costes del Transporte de Mercancías por Carretera" (National Observatory of Road Freight Transportation Costs) which is integrated by the Comité Nacional del Transporte por Carretera (National Committee for Road Transportation), main associations which represent docker companies (AECOC, AEUTRANSMER y TRANSPRIME) and Dirección General de Transporte Terrestre (Directorate General for Terrestrial Transportation).



Figure 33: ACOTRAM transportation cost calculator



In this programme different parameters related to technical characteristics (e.g. Power, gross vehicle weight rating, payload and number of axis) and operational characteristics of vehicles (e.g. kilometres covered in a year in load and empty, activity time and travelled tons) are introduced.

The screenshot shows the 'Cálculo Personalizado (21/09/2020)' window. It is divided into two main sections: 'Características técnicas del vehículo' and 'Características de explotación del vehículo'.  
**Características técnicas del vehículo:**  
 Descripción: Vehículo articulado de carga general.  
 Potencia: 428 CV, 315 kW.  
 Masa Máxima Autorizada (kg): 44.000.  
 Carga útil (kg): 28.000.  
 Número de ejes: 6.  
**Características de explotación del vehículo:**  
 Descripción: Recorridos en carga superiores a 200 km.  
 Kilómetros recorridos: 20.000 km.  
 Kilómetros recorridos anualmente en carga: 85,0% (102.000 km).  
 Kilómetros recorridos anualmente en vacío: 15,0% (18.000 km).  
**Tiempo de actividad:**  
 Horas trabajadas al año: 1.800.  
 Horas trabajadas al año en carga: 85,0% (1.530 horas).  
 Horas trabajadas al año en vacío: 15,0% (270 horas).  
 Días trabajados al año: 225.  
 Horas trabajados por jornada: 8,00.  
**Toneladas transportadas:**  
 Carga media en los kilómetros recorridos en carga: [Empty field].  
 Producción anual: [Empty field].

Figure 34: Parameters introduced in ACOTRAM

ACOTRAM gives an approximation of annual costs given the introduced parameters. However, in this case and for calculating the economic cost of the routes studied it is more interesting to know the cost per kilometre. In this context, ACOTRAM also gives the possibility of knowing with all these costs taken into account the cost per driven kilometre and hour.

As shown in (figure 35) cost per kilometre if load is travelled is of 1.21€/km. Multiplying this by the distances of both routes the result is the following:

Road	Distance	Operating cost
N-121-A	69.44 km	84.02€
A-15	91.59 km	110.82€

Table 10: Operating costs of N-121-A and A-15

This result could be incomplete, because it does an study based in statistics and does not take into account the particularities of both roads. For instance, in the case of N-121-A there are not tolls for trucks (even if they might be implemented in the future) whereas in the case of A-15 the expected cost because of tolls is of 7.14€. However, this continues being the most exact way found for calculating private operating costs of transportation. By the one hand, because it is a tool created by the Transportation Ministry itself and by the other hand because different parameters referred to the vehicle can be introduced. If the calculation was made manually, even if variable costs as fuel consumption and tolls could be determined easily, it would be difficult to calculate the value of fixed costs (e.g. maintenance costs, repairing costs, insurance, depreciation etc) for particular routes.

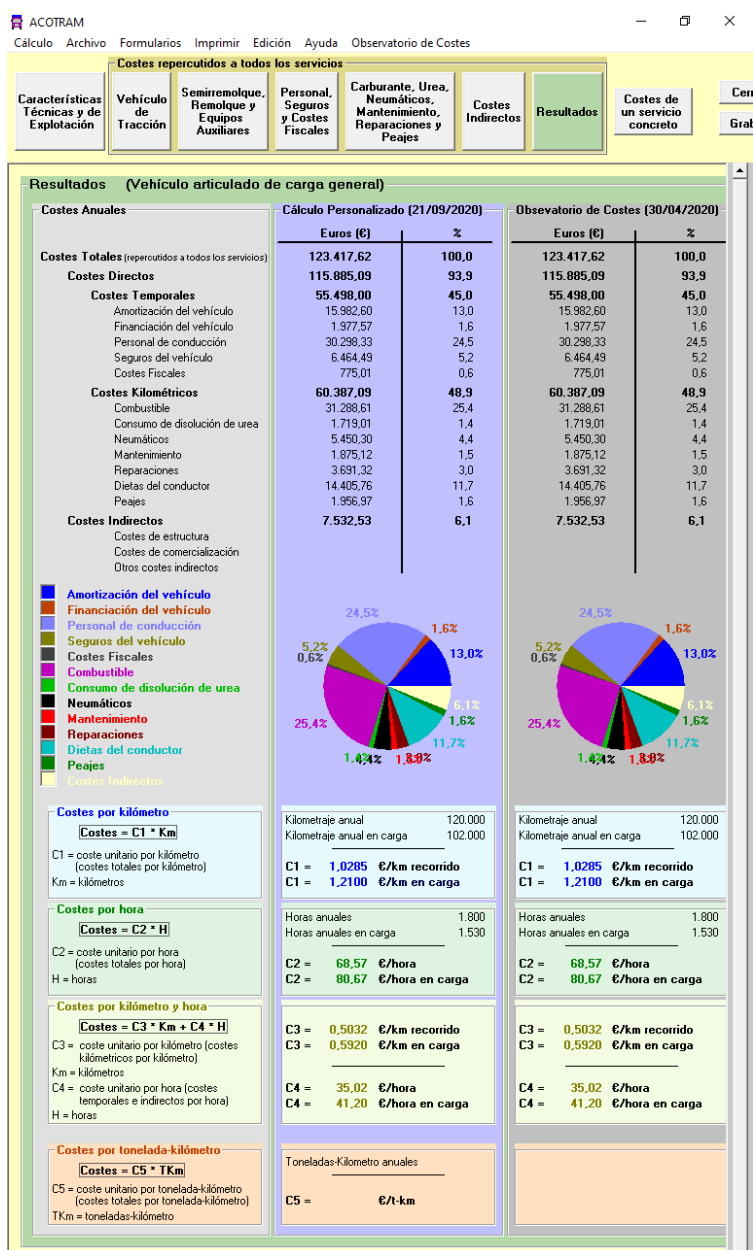

Figure 35: Results got with ACOTRAM

### 3.2. External costs

By the other hand, external costs are those that individual, firms or communities incur by as a result of an economic or social activity and have effect in other individuals, firms or communities but this impact is not fully accounted or compensated by the first group. They are also called third party costs or spillovers and can arise both from consumption and production. Some examples include the emission of pollutants during transportation or production activities or lack of fish stocks in the case of excessive fishing activities.

In freight transportation, external or social costs are an issue that affect its sustainability. These costs are the difference between social costs (all costs for society due to provision and use of transportation activities) and private costs (Costs directly borne by users). External costs can be source of market failure, inefficient allocation of resources, because these occur outside the market. Its desirable to internalize these costs because if so demand and supply equilibrium will occur in a sustainable level and because providers are more responsible with their decisions and customers use the services in a more efficient way. The market does not provide incentives for transport users to take external costs in account, and a result only a small part of them are taken in account. If these costs are internalized, externalities are part of the decision making process of transport users. This can be done through regulation (command and control measures) or by providing right incentives for transport users (taxes, charges, emission trading etc).

It is important also for governments to know until what extent these costs arise so they can design appropriate taxes and regulations, which are useful for limiting negative aspects of transportation and generating income for governments.

### **3.2.1. Average and marginal external costs**

Average external costs refer the costs per transport performance unit and are related to total external costs.

Marginal external costs are the additional external costs incurred due to additional transport activities. They are also divided in two types, short run which are linked to constant infrastructure capacity and long run, which take in account construction of additional traffic infrastructure.

The use of marginal or average costs depends on the scope of the project. If internalization is considered from an economic efficiency point of view marginal cost pricing should be used whereas from an equity point of view average costs should be taken in account, for assessing that transport sector or vehicle categories pay the costs they impose to society. For some externalities the value of average and marginal external costs are the same and do not depend in the size of the traffic flow, for instance a car entering a dense traffic flow emits the same level of pollutant compared to one entering a thin traffic flow. For other externalities though (accidents, noise and congestion) the costs depend on the density of the traffic flow. For instance, a car entering a road with free flow traffic has a marginal external congestion external cost than the average one and a car entering a road with its capacity almost met the external cost is much higher.

### 3.2.2. Calculation of external costs

In order to have an estimation of the external costs incurred in these routes the data will be retrieved from a report prepared by CE Delft for European Commission in 2019, “*Handbook on the external costs of transport, Version 2019*”.

CE Delft is an independent environmental research and consultancy organization specialised in giving solutions to environmental problems. This inform collects information about both average and marginal cost values for most important externalities (i.e. climate change, air pollution, accidents, noise, congestion, well to tank emissions and habitat damage), for all kind of vehicles in the road (from private cars to public transport vehicles and HGV-s), different types of roads (i.e. motorways, urban roads or other roads) and different areas (i.e. metropolitan, urban or rural).

Most externalities related to road freight transportation have been previous defined in 1.2.6 apart. However, there are some externalities considered in this study that have not been explained before:

**Well-to-tank emissions:** The rest of cost categories of externalities studied in this assessment cover direct effects of transport operation processes. However, there are upstream and downstream processes that are directly related to road transport and cause negative effects. These processes are located all along the life cycle of the transport process: The energy production, the vehicle and infrastructure production, maintenance and disposal processes which cause emission of pollutants, greenhouse gases, toxic substances and other negative impacts. The most relevant effects are related to energy production and are known as well-to-tank emissions. In the accounting of this extraction of energy sources, processing (refining or energy production), transport and transmission and building of energy plants and other infrastructure are taken in account.

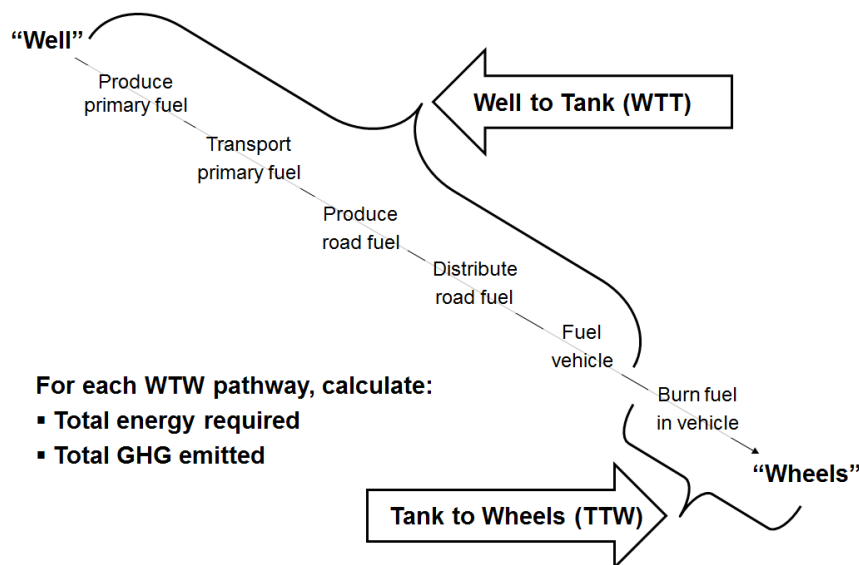

Figure 36: Well-to-tank (WTT) emissions (Source: EU Science Hub, European Commission)

**Habitat damage:** Transportation has negative effects on nature and landscape. They can be distinguished in two categories:

- **Habitat loss:** As transport infrastructure requires land or natural surfaces, when it is built leads to loss of natural ecosystems (which are habitats of plants and animals). This has an effect on biodiversity and even if occurs mainly during the building phase of the transport infrastructure it lasts over its whole lifetime.
- **Habitat fragmentation:** Transport infrastructure and transport demand in the infrastructure can cause additional fragmentation and separation effects for animals. This affects negatively the natural habitats of certain species and leads to negative effects for species and biodiversity. Main effects are caused in big infrastructures such as motorways and high-speed rail lines. Large wildlife mammals such as deers, rabbits etc and small animals as amphibians are affected by this phenomenon.
- **Habitat degradation due to emissions:** Habitat degradation can also occur because of the emission of pollutants of other toxic substances (e.g. heavy metals and PAH). These effects lead to biodiversity lost and external costs.

**Calculation assumptions:**

- The coefficients in “Handbook of External Costs of Transport” are given in different units, in the case they are given in vkm (vehicle kilometre) they only have to be multiplied by the distance travelled and of they are given in tkm (ton kilometre) they have to be multiplied by the distance and load (in tons) travelled.
- For average values, as all the externalities are given in both units its value will be calculated for both. In the case of marginal values, they are usually given in just one unit (tkm or vkm) so its value will be calculated only once.
- Traffic flow conditions will be considered as the standard situation in these roads, i.e. free flow conditions, in the main model. However, near capacity conditions will also be considered in order to study how indicators vary if this parameter changes and roads start to be collapsed.
- In the case that two different values are given in the table depending on different traffic situations, for instance thin or dense traffic conditions in the case of noise externality’s marginal value, average value between them will be taken in account.
- For some externalities in the case of the marginal costs it is considered the emission class of the vehicles to be Euro VI, the latest one included within this inform.
- In the case of habitat damage externality there is not value for marginal costs.

**A-15:**

Externality	Marginal Value				Average value			
	Unit	Other characteristics	Coefficient (€-cent)	Final value (€)	Unit	Other characteristics	Coefficient (€-cent)	Final value (€)
Climate change	vkm		0.43	0.33	tkm		0.53	13.59
					vkm		6.48	5.94
Air pollution	vkm		0.12	0.11	tkm		0.76	19.49
					vkm		9.38	8.59
Accidents	tkm		0.07	1.80	tkm		1.3	33.34
					vkm		15.5	14.20
Noise	tkm	Dense traffic	0	0	tkm		0.4	10.26
	tkm	Thin traffic	0.01	0.26	vkm		6.5	5.95
Congestion	tkm	Road near to full capacity	4.9	125.66	tkm	Near capacity, delay	0.06	1.54
					vkm	Near capacity, delay	0.88	0.81
	vkm	Road near to full capacity	66.3	60.72	vkm	Near capacity, deadweight loss	0.2	0.18
					tkm	Near capacity, deadweight loss	0.01	0.26
	vkm and tkm	Below capacity	0	0	vkm and tkm	Below capacity	0	0
Well-to-tank emissions	tkm		0.1	2.56	vkm		2.5	2.29
					tkm		0.2	5.14
Habitat damage	(No data)				vkm		2.4	2.20
					tkm		0.19	4.87
<b>Total (vkm)</b>	5.12€ (130.78 in case of near capacity conditions)				40.16€			
<b>Total (tkm)</b>	5.12€ (65.84 in case of near capacity conditions)				88.49€			

Table 11: Calculation of external costs for A-15 following "Handbook on the external costs of transport"

**N-121-A:**

Externality	Marginal Value				Average value			
	Unit	Other characteristics	Coefficient (€-cent)	Final value (€)	Unit	Other characteristics	Coefficient (€-cent)	Final value (€)
Climate change	vkm		0.47	0.33	tkm		0.53	10.30
					vkm		6.48	4.50
Air pollution	tkm		0.03	0.58	tkm		0.76	14.78
					vkm		9.38	6.51
Accidents	tkm		0.13	2.53	tkm		1.3	25.27
					vkm		15.5	10.76
Noise	tkm	Dense traffic	0	0	tkm		0.4	7.78
	tkm	Thin traffic	0.01	0.19	vkm		6.5	4.51
Congestion	tkm	Road near to full capacity	7.9	153.60	tkm	Near capacity, delay	0.8	15.55
					vkm	Near capacity, delay	10.9	7.57
	vkm	Road near to full capacity	107.1	74.37	vkm	Near capacity, deadweight loss	1.8	1.25
					tkm	Near capacity, deadweight loss	0.1	1.94
	vkm and tkm	Below capacity	0	0	vkm and tkm	Below capacity	0	0
Well-to-tank emissions	tkm		0.11	2.14	vkm		2.5	1.74
					tkm		0.2	3.89
Habitat damage	(No data)				vkm		2.4	1.67
					tkm		0.19	3.69
<b>Total (vkm)</b>	5.77€ (159.37€ in case of near capacity conditions)				38.51€			
<b>Total (tkm)</b>	5.77€ (80.14€ in case of near capacity conditions)				83.2€			

Table 12: Calculation of external costs for N-121-A following "Handbook on the external costs of transport"

# 4. MODELLING OF THE PROBLEM

## 4.1. Modelling of the routes

Both routes, N-121-A (in red) and A-15 (in yellow) are represented by using Google Earth. Google Earth is a very well-known tool that enables, in addition to many other functions, creating routes in a map.

The method used for creating the routes has been manually creating a track in Google Earth. For doing so, it is necessary to go point through point in order to create the most accurate route with the actual relief in which the roads go by. Google Earth catches thousands of points in the surface and its surface generates the height profile. As a result, it is a very useful tool because severe changes in gradients of the roads which affect to the speed of the trucks can be directly observed without the need of exporting the data to other programs. As a drawback it is true that in some areas where the roads go through viaducts the system does not recognize them and it supposes you go through the land underneath. However, when this happened it could be observed big leaps in the profile graphs so these areas were not taken in account.

Routes are represented in different segments between tunnels these roads have. Tunnels have been chosen as first boundaries to do a first definition of the routes for two reasons. The first reason is that they cannot be tracked with the method we have used (manually with Google Earth) and the second is because there all tunnels all along both roads so they are good reference points.

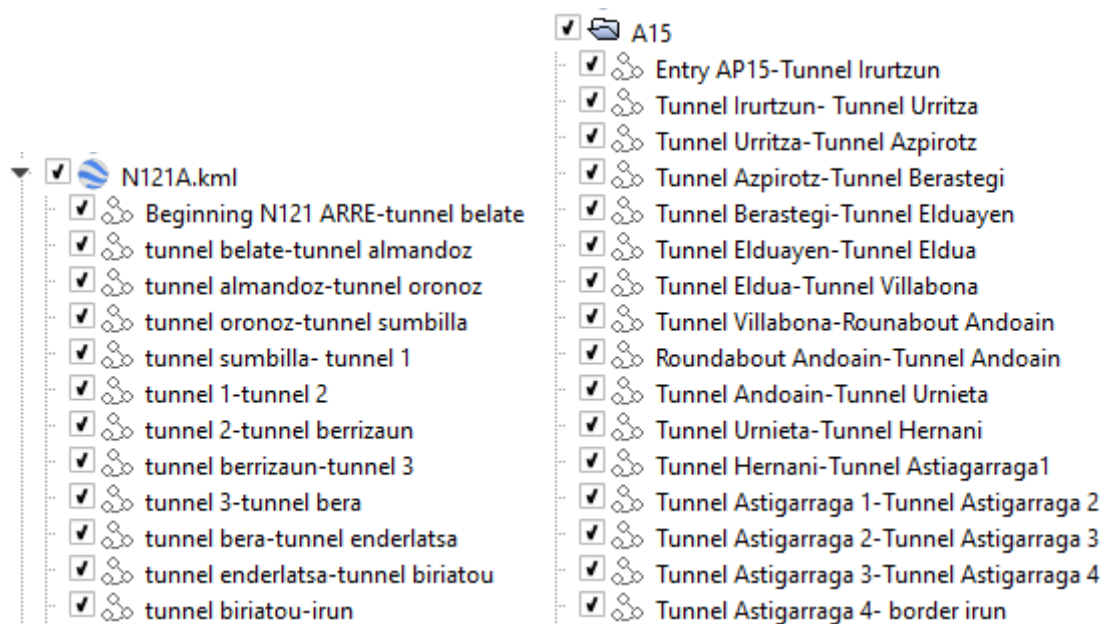

Figure 37: First division of both N-121-A and A-15 roads

Below we can see the different segments taken in account in order to represent the routes. The numbers in the routes represent the final segments in which the routes are divided because of the different speeds of the trucks through them. These segments have to be added to the tunnels, in which trucks have different speeds too.

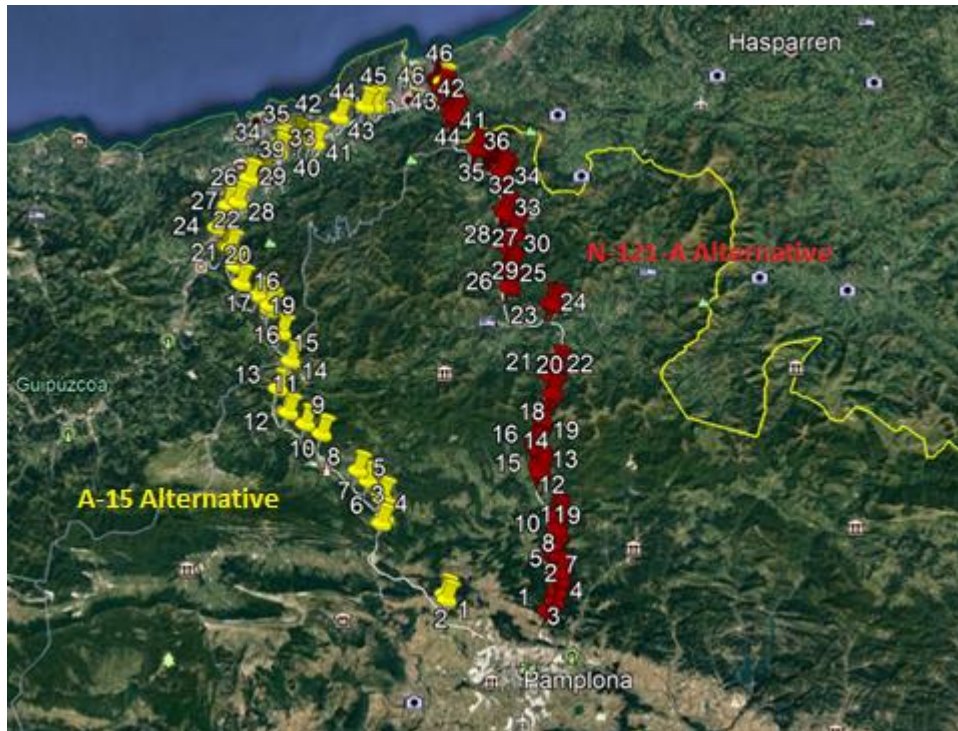

Figure 38: Different segments in which both roads were divided according to the speed of the trucks

#### 4.1.1. Calculation of Gradient and Speed Profiles of Roads

For doing the calculation of pollutant emissions of the two routes first thing to do is dividing the routes in different segments differentiated by their speed. Heavy trucks will especially suffer from gradients causing them a requirement of more power and consequently extra emissions in the case of positive gradients and the opposite in the case of negative gradients. Gradients have also a direct effect in the speed of the vehicles as mentioned before, so as with other factors (crossing urban areas, being close to urban areas, tunnels or crossroads) has to be considered in this analysis.

Slope is calculated using Google Earth, so a track is built for both roads (A-15 and its continuation in A-1, A-15 and AP-8 in Gipuzkoa and N121-A). First some segments are established from tunnel to tunnel for both roads, because tunnels cannot be tracked so easily and later will have different speed restrictions than other segments as the speed in them is usually more limited. Then the height is calculated in a km to km frequency in order to have the kilometrical profile of the roads. Seeing the profiles that Google Earth elaborates, if we notice that for a significant length the gradients are bigger than 2%



(both positive or negative) we can create a new segment in the second phase where road is divided by segments of similar speed. As said before other factors for changes in speed and consequently for creating a new segment in the second phase are urban areas, crossroads, tunnels or roundabouts.

Here are shown some profile elaborations in the first phase (from tunnel to tunnel).



Figure 39: Examples of elevation profiles got from N121-A using Google Earth, from the beginning of the route to Belate tunnel

Then, as said before, once the kilometrical segments are done; roads divided in segments according to the speed of the heavy trucks travelling in them. For N121A the road is divided in 47 different segments and in the case of A-15 it is divided in 46 segments.

The criteria to establish speed in N121-A road is the following one:

- In segments without any type of differential factor as gradients, intersection areas, urban areas or tunnels the speed for both roads is assumed of 90 km/h.
- In segments with tunnels the speed is assumed of 80 km/h (always that the tunnel is not inside of an urban area or has an average grade greater than 2%).
- In segments where urban areas are crossed the speed is assumed to be of 50 km/h and in those in which urban areas are left in a side of the road it is assumed to be of 70 km/h.
- In segments with any of the features with curves speed is assumed to be of 70 km/h.
- In the case of gradients greater than 2% the speed is calculated searching in the literature (Aashto, 1994) the speed profiles according to the lengths and percentages of the gradients (Figure 32). As it can be seen in the graph the curves affecting the speed of the vehicles start having an effect since gradients of 2%. It can also be observed that the speed of the heavy vehicles in the gradients gets constant after approximately 3000 metres, but gradients are generally not so long as this distance in both these roads.

The criteria to establish speed in N121-A roads are the following one:

- In segments without any type of differential factor as gradients, intersection areas, urban areas or tunnels the speed for both roads is assumed of 90 km/h.
- In segments with tunnels the speed was assumed of 80 km/h (always that the tunnel is not inside of an urban area or has an average grade greater than 2%).

- In areas approximating to toll paying points speed was considered to be of 30km/h. It is assumed that there is ideal condition, so no big traffic and trucks do not have to stop to pay the toll because they have electronic toll collection systems (ETC).
- In exits and turn-offs to other roads/highways speed is considered to be of 70 km/h.
- In the case of gradients greater than 2% the speed is calculated searching in the literature (Ashto) the speed profiles according to the lengths and percentages of the gradients (Figure 32). As it can be seen in the graph the curves affecting the speed of the vehicles start having an effect since gradients of 2%. It can also be observed that the speed of the heavy vehicles in the gradients gets constant after approximately 3000 metres, but gradients are generally not so long as this distance in both these roads.

In order to get information about the actual changes in speed limits of the roads and different features Google Street View software is used.



Figure 40: View of N-121-A with Google Street View

## 4.2. Modelling of the vehicle

Emission calculation models that have been used require some realistic parameters. This is why some real vehicles by leading manufacturers in the sector have been considered in order to build estimations that are accurate and close to reality.

### 4.2.1. Tractor unit

As a tractor unit a model of DAF manufacturer is used, one of the main manufacturers of trucks in Europe with a market share of 13% in 2016 (European Environment Agency). DAF is a truck manufacturer based in Eindhoven (Netherlands) and a division of Paccar industry.

The model in this case is the tractor XF 430 FTT 6x4 Tractor



Figure 41: DAF XF 430 FTT 6x4 Tractor

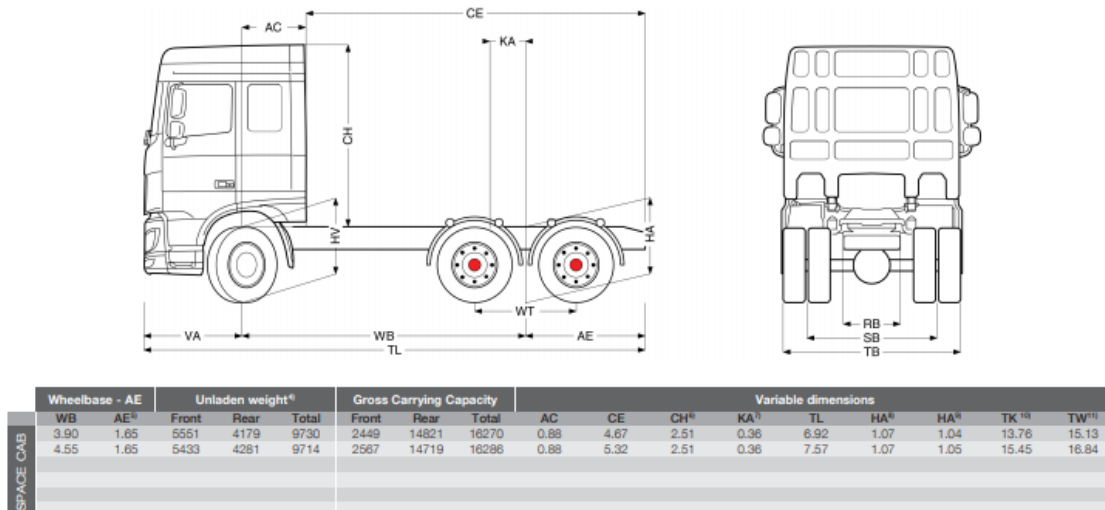

ENGINES
XF 430 MX-13 (315 kW / 428 hp)
XF 480 MX-13 (355 kW / 483 hp)
XF 530 MX-13 (390 kW / 530 hp)

GVM <sup>1)</sup>	GCM <sup>2)</sup>
26000 kg	44000 kg
Max. front 8000 kg	
Max. rear 19000 kg	

Figure 42: DAF XF 430 FTT 6x4 Tractor specifications

As can be seen when unloaded this trailer has a weight of 9730 kg and offers the possibility of having GVM (Gross Vehicle Mass) of 26000 kg and a GCM (Gross Combination Mass) of 44000 kg.

#### 4.2.2. Semi-trailer

As a semi-trailer a tautliner type one is used, which is the most typical set-up for semi-trailers. In this case the manufacturer chosen is the German Schmitz Cargobull, one of the main manufacturers of semi-trailers, trailers and truck bodies.

S.CS Mega X-Light model is chosen, which has an unloaded weight of 6060 kg.



Figure 43: Schmitz Cargobull semi-trailer

Payload calculation examples:	Unloaded semi-trailer weight**
S.CS MEGA X-LIGHT	6,060 kg
S.CS UNIVERSAL X-LIGHT	5,410 kg
S.CS PAPER X-LIGHT	6,190 kg
S.CS COIL X-LIGHT	6,490 kg

Figure 44: Schmitz Cargobull semi-trailer specifications

As a result, with these two models of tractor unit and semi-trailer the weight of the whole unit would be of 15.79 tons.

### 4.3. Modelling of emission calculation (Applied models)

#### 4.3.1. MODEL 1: Instantaneous Fuel Consumption Model

This method was developed by Bowyer et al. in 1985 as an extension to Kent et al.'s power model of 1982.

It uses different parameters as mass, energy, efficiency parameters, drag force and fuel consumption components (which are associated with aerodynamic drag and rolling resistance). Fuel consumption is approximated to time lapses lasting one second.

It takes the following form:

$$f_t = \begin{cases} \alpha + \beta_1 R_t v + \left( \frac{\beta_2 M a^2 v}{1000} \right) & \text{for } R_t > 0 \\ \alpha & \text{for } R_t \leq 0 \end{cases} \quad (4)$$

Where:

$\alpha$ : Constant idle fuel rate (ml/s) (between 0.375 and 0.556)

$\beta_1$ : Fuel consumption per unit of energy (ml/kJ) (Between 0.09 and 0.08)

$\beta_2$ : Fuel consumption per unit of energy-acceleration (ml/(kJms<sup>2</sup>)) (Between 0.09 and 0.08)

$f_t$ : Fuel consumption (ml/s)

$v$ : Speed (m/s)

$a$ : Instantaneous acceleration (m/s<sup>2</sup>)

$R_t$ : Tractive force to move the vehicle (KN). Sum of the drag force, inertia force and grade force.

$$R_t = b_1 + b_2 v^2 + \frac{Ma}{1000} + gM\omega/100,000 \quad (5)$$

Where:

b1: Rolling drag force (KN) (0.1-0.7)

b2: Rolling aerodynamic force (kN/(m/s<sup>2</sup>)) (Between 0.00003-0.0015)

$\omega$ : Percent grade

M: Weight (kg)

For a travel of a length  $t_0$  the fuel consumption will be the following one:

$$F_{t=\int_0^{t_0} f_t dt} \quad (6)$$

#### 4.3.2. MODEL 2: Methodology for Calculating Transportation Emissions and Energy Consumption (MEET)

With this procedure, emissions are calculated in the following way:

$$E = E_{hot} + E_{start} + E_{evaporative} \quad (7)$$

Where:

$E$ : Total emissions

$E_{hot}$ : Emissions with hot engine

$E_{start}$ : Emissions with cold engine

$E_{evaporative}$ : Emissions for evaporation

$$\text{In general} \rightarrow E_x = e_x \times a \quad (8)$$

Where:

$E_x$ : A contributor to total emissions

$e_x$ : Emission factor related to activity

a: Quantity of traffic activity related to this kind of emission

The combustion of hydrocarbon (gasoline, diesel, CNG) in air, in ideal conditions, follows the next equation:



With molecular weights you can calculate  $H_2O$  and  $CO_2$  produced with some quantity  $x$  of fuel.

In real conditions combustion is not produced following the ideal equation:

- Part of the carbon is not completely oxidized (Emitted as CO or as particles of carbon (PM)).
- There is some fuel that avoids combustion (Emitted as VOC).
- $NO_x \rightarrow$  Oxidation of nitrogen in air and parts in fuel itself.

Carbone balance to calculate fuel consumption:

$$(\text{Fuel mass})=12 + r1 \times \left(\frac{(CO_2)}{44} + \frac{(CO)}{28} + \frac{(HC)}{12+r2} + \frac{a(PM)}{12}\right) \quad (10)$$

$r1/r2 \rightarrow$  Hydrogen to carbon ratio of fuel and HC emissions

#### 4.3.2.1. General Equations

$$E_{hot} = e \times m \quad (11)$$

$$m = n \times l \quad (12)$$

Where:

$E_{hot}$ : Emission (Mass per unit time)  $\left(\frac{t}{a}\right)$

$e$ : Hot emission factor  $\left(\frac{g}{km}\right)$

$m$ : Activity, distance x unit of time  $\left(\frac{km}{a}\right)$

$n$ : Number of vehicles for each category of table A5

$l$ : Medium distance calculated for medium vehicle of category

	<b>K</b>	<b>a</b>	<b>b</b>	<b>c</b>	<b>d</b>	<b>e</b>	<b>f</b>
<i>CO</i>	1.53	0	0	0	60.6	117	0
<i>CO<sub>2</sub></i>	765	-7.04	0	0.000632	8334	0	0
VOC	0.207	0	0	0	58.3	0	0
<i>NO<sub>x</sub></i>	9.45	-0.107	0	7.55E-6	132	0	0
PM	0.184	0	0	1.72E-7	15.2	0	0

Table 13: Coefficients of emission functions for heavy goods vehicles with gross vehicle weights from 16 to 32 tonnes (MEET)

#### 4.3.2.2. Heavy vehicles

##### General equation:

It has in account the following pollutants: *CO*, *CO<sub>2</sub>* hydrocarbons, nitric oxides and particulates. Also takes in account 4 types of heavy vehicles according their load.

$$\varepsilon = k + a \cdot v + b \cdot v^2 + c \cdot v^3 + \frac{d}{v} + \frac{e}{v^2} + \frac{f}{v^3} \quad (13)$$

Where:

$\varepsilon$ : Emission ratio (g/km) vehicle without load, with 0% gradient

$k$ : Constant value

a-f: Coefficients (Tables A-24 and A-27) dependent in the type of the vehicle

v: Mean speed of the vehicle

##### Gradient coefficient:

For every vehicle category, gradient and pollutant:

$$GC = aS_{i,j,k} = A6_{i,j,k} \cdot v^6 + A5_{i,j,k} \cdot v^5 + A5_{i,j,k} \cdot v^5 + A4_{i,j,k} \cdot v^4 + A3_{i,j,k} \cdot v^3 + A2_{i,j,k} \cdot v^2 + A1_{i,j,k} \cdot v + A0 \quad (14)$$

Where:

$aS_{i,j,k}$ : Correction factor

v: Mean speed of the vehicle

$A_{i,j,k}$ : Constants for each pollutant, vehicle and grade



$$eC_{hot,i,j,k} = aS_{i,j,k} \cdot e_{hot,i,j,k} \quad (15)$$

Where:

$eC_{hot,i,j,k}$ : Corrected emission factor of pollutant “I” (g/km), of “j” category vehicle, ridden in type k roads with hot engines.

$e_{hot,i,j,k}$ : Emission factor of pollutant “I” (g/km), of “j” category vehicle, ridden in type k roads with hot engines for 0% gradients.

$aS_{i,j,k}$ : Grade correction factor of “I” pollutant for “j” category vehicle driven in type “k” roads for an appropriate gradient class. (Gradient classes: 0%, 2%, 4%, 6%, -2%, -4%, -6%).

A6	A5	A4	A3	A2	A1	A0	Pollutant	Slope(%)	Vmin (km/h)	Vmax (km/h)
0.00E+00	5.88E-07	-7.24E-05	3.45E-03	-7.86E-02	8.63E-01	-9.76E-01	CO2	4... 6	12.4	35.0
0.00E+00	-1.18E-07	2.00E-05	-1.29E-03	3.96E-02	-5.78E-01	3.72E+00		-6... -4	13.5	49.9
0.00E+00	-2.04E-09	4.35E-07	-3.69E-05	1.69E-03	3.16E-02	-1.77E+00		0... 4	14.8	66.3
0.00E+00	-1.10E-09	2.69E-07	-2.38E-05	9.51E-04	-2.24E-02	9.16E-01		-4... 0	15.1	86.3

Table 14: Coefficients of gradient factor functions for heavy duty vehicles 16t<32t(MEET)

Vehicle load coefficient:

$$LC = \varepsilon_l = \varepsilon_u \cdot \phi(\gamma, v) \quad (16)$$

Where:

$\varepsilon_l$ : Emission factor when loaded (g/km)

$\varepsilon_u$ : Emission factor when unloaded (g/km)

$\phi(\gamma, v)$ : Function of load correction

$\gamma$ : Percent of grade

$v$ : Mean speed of the vehicle (km/h)

$$\phi(\gamma, v) = k + n \cdot \gamma + p \cdot \gamma^2 + q \cdot \gamma^3 + r \cdot v + s \cdot v^2 + t \cdot v^3 + \frac{u}{v} \quad (17)$$

Where:

K: Constant

n-u: Coefficients

	<b>k</b>	<b>n</b>	<b>p</b>	<b>q</b>	<b>r</b>	<b>s</b>	<b>t</b>	<b>u</b>
<i>CO</i>	1.17	0.0563	0	-8.19E-4	0	0	0	-0.755
<i>CO<sub>2</sub></i>	1.27	0.0882	0	-0.00101	0	0	0	-0.483
VOC	1.01	-0.00660	0	2.09E-4	8.89E-4	0	-2.54E-7	0
<i>NO<sub>x</sub></i>	1.28	0.0795	-0.00105	-0.00117	0	0	0	-0.874
PM	1.24	0.0727	0	-0.00113	0	0	0	-1.06

Table 15: Coefficients for load correction functions for HGVs from 16 to 32 tons (MEET)

Final equation:

Finally, general equation needs to be multiplied for the gradient and load coefficients respectively.

$$F = \varepsilon \cdot GC \cdot LC \cdot Distance \quad (18)$$

### 4.3.3. MODEL 3: Comprehensive modal emission model

This model was developed by Barth et al. (2000, 2005) and Barth and Boriboonsomsin (2008). It consists in three modules: energy power, energy speed and fuel rate.

#### 4.3.3.1. Engine power module

Demand function of the vehicle obtained from the tractive power requirements  $P_{tract}$  placed on vehicle at its wheels:

$$P_{tract} = \left( M \cdot a + M \cdot g \cdot \sin\theta + \frac{1}{2} \cdot C_d \cdot A \cdot \rho \cdot v + M \cdot g \cdot v \cdot C_r \cdot \cos\theta \right) \cdot v/1000 \quad (19)$$

Where:

V: speed (m/s)

M: Weight (kg)

$\rho$ : Air density (kg/m<sup>3</sup>)

A: Frontal area of the surface (m<sup>2</sup>)

g: Gravitational constant ( $m/s^2$ )

$C_d$ : Drag coefficient

$C_r$ : Rolling resistance coefficient

In order to translate tractive requirement into engine power requirement the following equation is used:

$$P = \frac{P_{tract}}{\varepsilon} + P_{acc} \quad (20)$$

Where:

P: Second-by-second engine power output (Kw)

$\eta_{tf}$ : Vehicle drive train efficiency

$P_{acc}$ : Engine power demand associated with running losses of the engine and accessories of the vehicle such as air conditioning

#### 4.3.3.2. Engine speed module

In order to approximate the engine speed to vehicle speed the following equation is used:

$$N(t) = S \cdot \frac{R(L)}{R(L_g)} \cdot v(t) \quad (21)$$

Where:

N: Engine speed (rpm)

S: Engine-speed/ vehicle speed ratio in top gear  $L_g$

R(L): Gear ratio in gear  $L=1, \dots, L_g$

v: Vehicle speed (m/s)

C: Efficiency parameter for diesel engines

#### 4.3.3.3. Fuel rate module

The fuel rate (g/s) is given by this expression:

$$FR = \phi(kNV + P/\phi)/44$$

Where:

$\phi$ : Fuel-to-air mass ratio

$k$ : Engine friction factor

$V$ : Engine displacement (litres)

#### 4.3.4. Assumptions for the models

For all models:

- For the loads travelled by the heavy trucks we will use the same for both roads N121 and A15. Statistically the average loads of both roads are different, but in order to do a fair comparison we need to set the same parameters for both roads. According to data provided by “*Observatorio hispano-francés de Tráfico en los Pirineos*” in their last report available of May 2018 the average load of trucks coming from AP-8 (which is the natural border crossing motorway coming from A-15) is of 15,1 tons whereas for Basque-bridges (bridges in Irún which are the natural border crossing points coming from N-121a) was of 9.3 tons. Having in account the previous considerations the load considered for the calculations will be of an average value of these previous two values of 12.2 tons. The value of the generic model considered of a tractor + semi-trailer of these characteristics is of 15,79 tons when unloaded. As a result, total weight of the truck considered (unloaded + load) will be of 27.99 tons, 28 tons to round the figure.
- Even if there are situations in which the trucks might need to stop, for example in intersections between two roads if there is traffic, we will develop a model in which the trucks don't stop at any time. As our routes go through non-urban areas this estimation is feasible, obviously taking in account the different speed restrictions along both roads.

For Model 1:

- We estimate that the speed of the trucks, as heavy vehicles they are, is constant. As a result, the acceleration component of the equations is zero when using the “Instantaneous Fuel Consumption Model”. We can make this

estimate because heavy trucks do not usually experiment big speed changes as they transport heavy loads.

- For the cases of the  $\beta_1$ ,  $\beta_2$ ,  $b_1$ ,  $b_2$  and  $\alpha$  coefficients we will use the average values of the maximum and minimum values included in the model, so we can calculate the values of this coefficient for a generic heavy truck.
- All the gradients are considered in this model, in the case of negative gradients the tractive force is also negative so we consider instantaneous fuel consumption as  $\alpha$  (constant idle fuel rate).

#### For Model 2:

- For the calculation of a-f coefficients the mass of the vehicle is necessary. Also coefficients are different for different kinds of pollutants. In this case the study will be done for  $CO_2$  emissions because it is the most significant pollutant caused from road transportation.
- We consider gradients greater than 2% or -2% in order to apply the grade coefficient. Gradients with lower percentages will not have a significant impact in the fuel consumption so their coefficient will be kept as 1 (as if the grade was of 0%). We do it in this way because gradients are considered in intervals for the case of the grade correction coefficient of [-6, -4], [-4-0], [0,4] and [4,6].
- For the case of correction due to load coefficient all the gradients are included because grade needs to be introduced as a value in the equation and not as an interval.
- When searching for the parameters that have to be introduced in the equations values will be found for category “heavy good vehicles with gross vehicle weights from 16 to 32 tons”.

#### For Model 3:

- We do the calculations for a DAF XF 430 FTT 6x4 Tractor we had chosen as a prototype model, as this model requires very specific data of transmission relations and this manufacturer offers many information.
- We had some problems with the gear ratio data because the truck tractor unit chosen, the DAF XF 430 FTT 6X4, has a Paccar MX-13 engine with 12 speeds. In the literature we only could find gear ratios for a MX-13 model of 10 gears, however we make a supposition that the results will not vary much because of this issue.
- As explained in the specifications of the engine, the recommended rpm of the engine for the most efficient fuel consumption is between 1150 and 1300 rpm. As a result, for every speed in the different sections in which both roads are divided it is selected the speed which led to values in this range and in the case

it is not possible the most similar ones. Examples of gears used for different speed values are the following ones:

- For speed of 90km/h the 10<sup>th</sup> gear is used.
- For speeds of 70-80 km/h the 9<sup>th</sup> gear is used.
- For speeds of 50-60 km/h the 8<sup>th</sup> gear is used.
- For speed of 30 km/h the 6<sup>th</sup> gear is used.

- To get the speed of the engine in rpm first we had to take in account the radius of the trucks' wheels, in this case of 0.505m (figure 46). Then we had to multiply it with the axle ratio and the gear ratio of the accurate speed in order to get this result.

Gear	Ratio	%Step
10th	0.80	28
9th	1.00	42
8th	1.42	43
7th	2.03	39
6th	2.83	40
5th	3.97	26
4th	4.98	42
3rd	7.06	43
2nd	10.12	39
1st	14.11	
Hi REV	3.43	
Lo REV	17.12	
Overall	17.7	
<b>Recommended RPM band (cruise speed)</b>		
1150-1300 rpm		

Table 16: Gear ratios for MX-13 and recommended RPM band

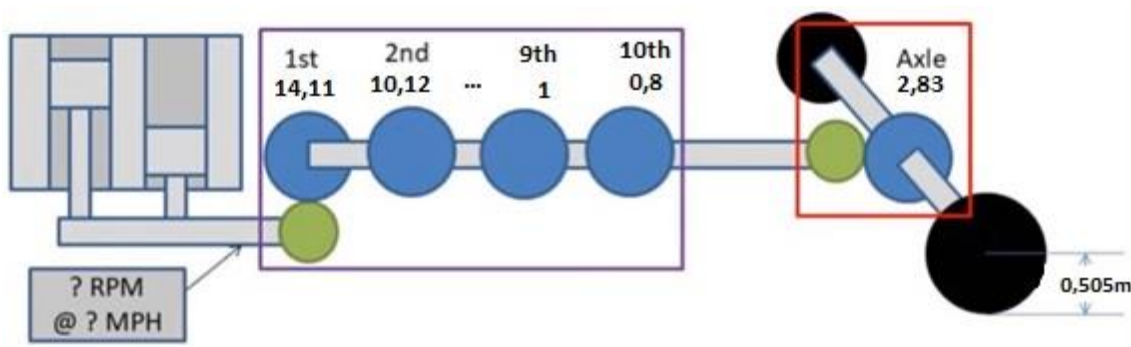

Figure 45: Relation between wheels speed and engine speed

## DRIVELINE

Engine MX-13, multi torque 6 cylinder diesel engine, 12.9 litres.  
Output 315 kW (428 hp) at 1600 rpm. Maximum torque 2300 Nm at 900-1125 rpm.; Exhaust emission Euro 6; Engine idle shutdown, 5 minutes; Automated gearbox, TraXon, 12 speeds; Gearbox ratio 16.69-1.00; Rear axle ratio 2.83; ASR.

### Optional

**04523** Manual gearbox, 16 speeds      **02314** Gearbox overdrive

**07103** Automated gearbox, TraXon, 16 speeds

Figure 46: Information about the driveline of MX-13 engine

- In order to calculate frontal surface area measures given by DAF manufacturer for the dimensions of frontal part and wheels are used. Using the diagrams seen in the pictures before frontal area is calculated of 9.079 m.<sup>2</sup>

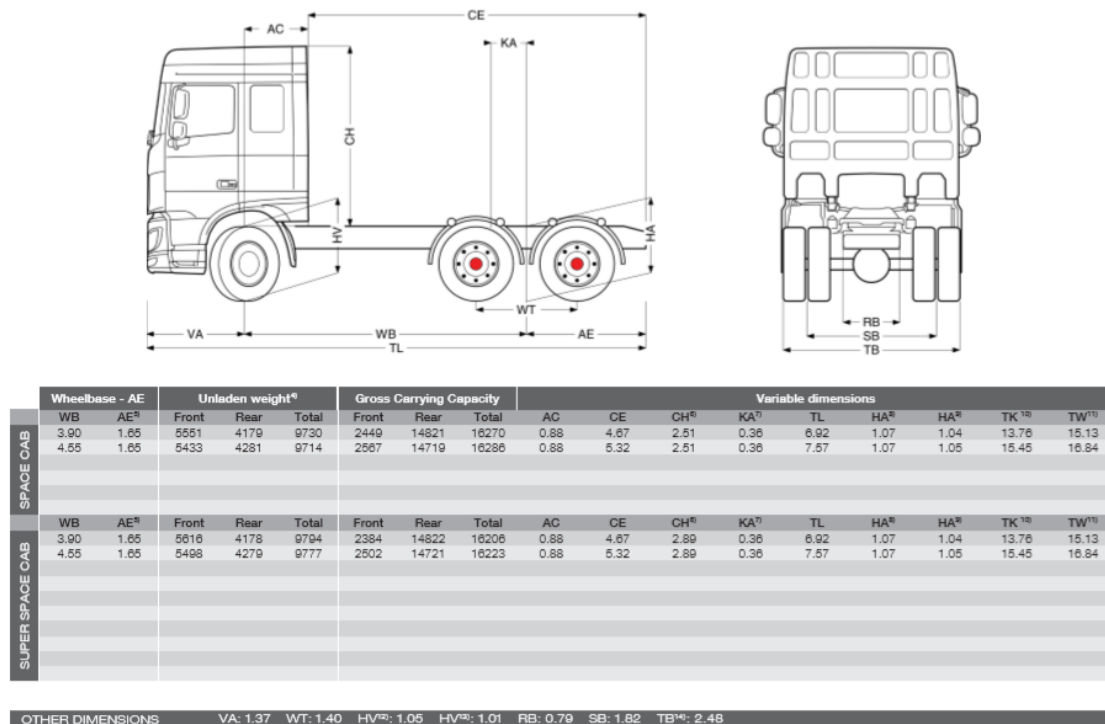

Figure 47: Dimensions of DAF XF 30 used to calculate frontal area

- Other parameters contained in the equations are settled as they appear in the model or found in the literature. For example:
  - $k$  (Engine friction factor) = 0.2
  - $\eta$  (Efficiency parameter) = 0.4
  - $C_d$  (Drag coefficient) = 0.7
  - $C_r$  (Rolling resistance coefficient) = 0.01
  - $\rho$  (Air density) = 1.2041 kg/  $m^3$
  - $g$  (Gravitational constant) = 9.81 m/  $s^2$
  - $\varphi$  (Fuel-to-air mass ratio) = 14.5/1



## 5. RESULTS

Results that were got using different estimation methods explained in 4.3 apart are included in this section. As well, a sensitivity analysis will be performed in order to verify how changes in different parameters related to the models affect the outcome of the emission values.

### 5.1. Results for model 1

Results in instantaneous model are much lower than what it could be expected for trucks of these characteristics. Consequently, these results will not be taken in account in the analysis of the solution of the problem. This happened because it is a model focused in smaller vehicles and mainly for urban areas, so is not so accurate for our case (heavy truck transportation in non-urban areas).

### 5.2. Results for model 2

We got the results from model 2 in function of  $CO_2$  grams generated, so in order to compare the results in the same unit to the ones obtained with instantaneous model we pass it to litres of combustible. To do this conversion we need to have in account the type of fuel used in Europe. According to European Automobile Manufacturers' Association (ACEA) 98% heavy vehicles registered in Europe in 2019 are diesel whereas the gasoline vehicles are only 235 and represented a share of only 0.1%. As a result, it is quite clear that diesel heavy trucks are the most usual ones in Europe by a huge difference.

First a manual conversion has been done and later this conversion has been compared to those appearing in literature. For achieving a manual conversion chemical formulation of combustion is used (20), which allows calculating how many molecules of  $CO_2$  are obtained from a molecule of diesel, having in account both's molecular mass.

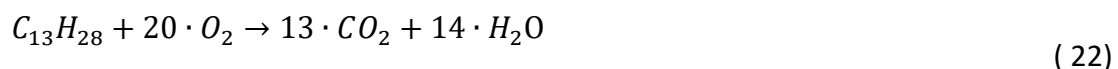

If the conversion needs to be done manually the value will range depending of the molecular mass of the chosen diesel. Molecular mass of diesel ranges between 170 and 200, in this case a standard diesel molecule with 184 molecular mass will be chosen. It is also known that molecular mass of  $CO_2$  is 44 and for each molecule of diesel there are 13 molecules of  $CO_2$ . For every kg of diesel consumed 3.11 kg of  $CO_2$  are emitted. Lastly, as stated in literature the density of diesel is 0.84 kg/litre, it can be calculated that 2.61 kg of  $CO_2$  are emitted for each litre of diesel consumed (conversion factor of diesel fuel).

$$\frac{13 \times 44}{184} = 3.11 \frac{kg CO_2}{kg diesel} \times 0.84 \frac{kg diesel}{litre diesel} = 2.61 \frac{kg CO_2}{litre diesel} \quad (23)$$

Other indicators give slightly different values but all of them are within this range. For instance, a study led by IEEP (Institute for European Environmental Policy) for European Commission states CO<sub>2</sub> emissions per litre of diesel burned in 2.67 kg-s. In our calculations a value of 2.64 has been used (the one provided in Ecoscore.be source) which is an average value between the manual calculation and the value provided by IEEP.

CO <sub>2</sub> emissions per litre of diesel burned (kg)	
Value	Source
2.61	Manual calculation
2.63	Netcen
2.6391	Comcar.co.uk
2.64	Ecoscore.be
2.67	IEEP
2.68	University of Exeter

Table 17: CO<sub>2</sub> emissions per litre of diesel burnt according to different sources in literature

- **N121-A:**

By summing up all the sections in which the road is divided we get a result of 59800,28 grams of CO<sub>2</sub> combusted, which means an amount of 662,09 g CO<sub>2</sub>/km. If we do the equivalency explained before (2640g CO<sub>2</sub>= 1 litre diesel) we get that 22,65 litres of diesel are combusted in this route. As routes have different distances the result can be also given in litres of diesel combusted every 100 km. In this case for this route the amount is of 32.62 l comb/100 km.

- **A-15:**

By summing up all the sections in which the road is divided we get a result of 82512.12 grams of CO<sub>2</sub> combusted, which means an amount of 720.07 g CO<sub>2</sub>/km. If we do the equivalency explained before (2640g CO<sub>2</sub>= 1 litre diesel) we get that 31.25 litres of diesel are combusted in this route. As routes have different distances the result can be also given in litres of diesel combusted every 100 km. In this case for this route the amount is of 34.12 l comb/100 km.

As a result, from a merely ecological point of view N121-A is a much better route, because enables doing the same journey in a much shorter distance (by more than 20 km) and even per kilometre the litres of diesel emitted are lower (25.05 l/100 km vs 27.27 l/100 km).

### 5.3. Results for model 3

- N121-A:

By summing up all the sections in which the road is divided we get a result of 64278,32 grams of  $CO_2$  combusted, which means an amount of 925.67 g  $CO_2$ /km. If we do the equivalency explained before (2640g  $CO_2$ = 1 litre diesel) we get that 24.35 litres of diesel are combusted in this route.

- A-15:

By summing up all the sections in which the road is divided we get a result of 75074.53 grams of  $CO_2$  combusted, which means an amount of 820.22 g  $CO_2$ /km. If we do the equivalency explained before (2640g  $CO_2$ = 1 litre diesel) we get that 28.44 litres of diesel are combusted in this route.

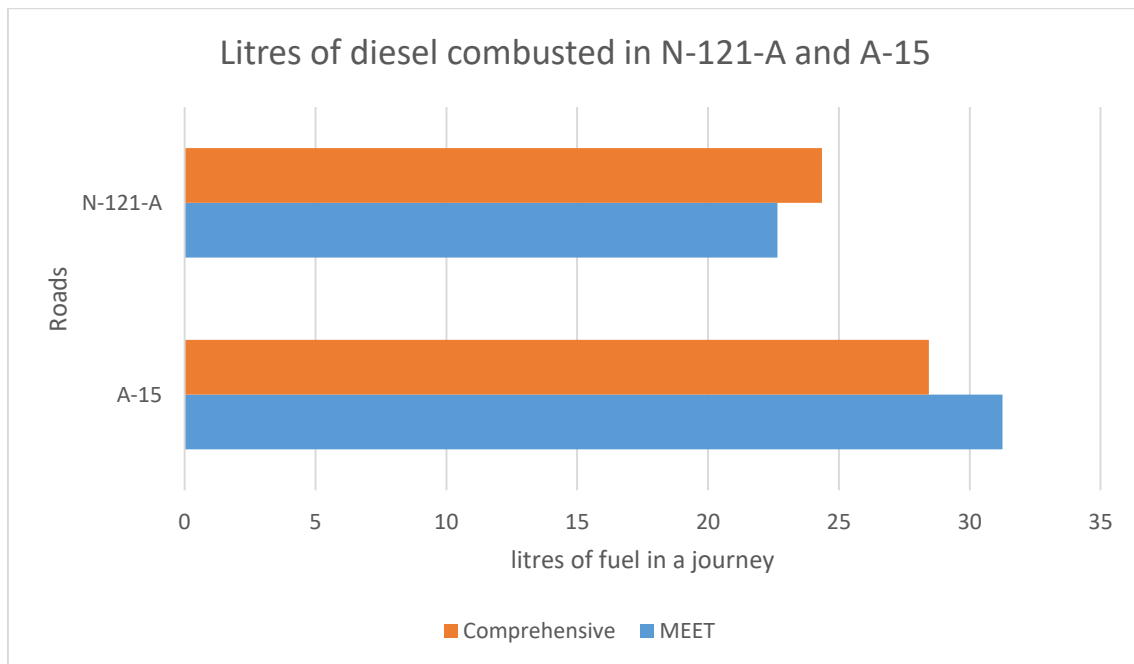

Figure 48: Litres of diesel combusted in N-121-A and A-15 in defined conditions

	<b>MEET</b>	<b>Comprehensive</b>
<b>A-15</b>	31.25	28.44
<b>N-121-A</b>	22.65	24.35

Table 18: Litres of diesel combusted in N-121-A and A-15 in defined condition

## 5.4. Sensitivity analysis

### 5.4.1. Change in the shape of the vehicle (Drag coefficient)

If the shape of the vehicle changes and the vehicle under study is not a conventional tractor and semitrailer unit, the drag coefficient of it will change. First the concept of drag coefficient needs to be explained, being this a concept used in fluid dynamics.

Drag coefficient (which is commonly denoted as:  $C_d$ ,  $C_x$  or  $C_w$ ) is a dimensionless quantity used to quantify the drag or resistance of objects in fluid environments such as air or water. A lower drag coefficient indicates that the object has less aerodynamic or hydrodynamic drag, being this parameter used in the drag equation. The drag coefficient is associated to particular surface areas or shapes, in consequence, different shapes have different drag coefficients.

There are two main contributors to fluid dynamic of an object: skin friction and form drag. In the case of the drag coefficient of a lifting airfoil lift-induced drag also appears and in the case of the drag coefficient of a complete structure such as an aircraft the effects of interference drag also appear.

The drag coefficient can be defined as:

$$c_d = \frac{2F_d}{\rho u^2 A} \quad (24)$$

Where:

$F_d$ : Drag force

$\rho$ : Mass density of the fluid

$u$ : Flow speed of the object relative to the fluid

$A$ : Reference area

Different dispositions of trucks have different drag coefficients, as a result parameters of drag coefficient will be changed for the case of a car hauler truck and a garbage truck. Parameters referred to the weight will be kept constant.

Shape	Drag Coefficient
Sphere	0.47
Half-sphere	0.42
Cone	0.50
Cube	1.05
Angled Cube	0.80
Long Cylinder	0.82
Short Cylinder	1.15
Streamlined Body	0.04
Streamlined Half-body	0.09

Measured Drag Coefficients

Figure 49: Drag coefficient in fluids with Reynolds number approximately of  $10^4$

Truck type	$c_d$	Source
Single unit	0.70	Fitch(1994)
Tractor-semitrailer	0.70	Fitch(1994)
Car hauler – cattle hauler	0.96-1.10	SAE J2188
Garbage	0.95-1-05	SAE J2188
No aerodynamic aids	0.78	SAE J2188
Aerodynamic aids on roof	0.64	SAE J2188
Full aerodynamic treatment	0.58	SAE J2188

Table 19: Drag coefficients for different truck types

	Car hauler	Garbage
<b>A-15</b>	29.06	29.04
<b>N-121-A</b>	24.58	24.56

Table 20: Litres of diesel combusted in N-121-A and A-15 for different geometries with their drag coefficients in Comprehensive method

Drag coefficient is only a parameter that can be changed in the comprehensive method, not in MEET method. However, as it can be checked, a change in the drag coefficient does not cause a significant change in fuel consumption.

#### 5.4.2. Using an unloaded vehicle (tractor and empty semitrailer)

Many trucks return from their deliveries and have to do this journey without any load. “Between 20% and 30% of truck travel involves repositioning empty vehicles.” (Ranaiefar, Regan). Efficiency in truck transportation tries to diminish these kind of travels as much as possible but it is impossible to avoid them at all. This is the reason why it has to be studied how the results vary if instead of the load considered before the semi-trailer is empty. The tractor and semi-trailer unit considered will be the same it was used before. Consequently, the total weight of the tractor unit and the semi-trailer will be of 15.79 tons (9.73 tons of the tractor unit plus 6.06 tons of the semi-trailer).

In this scenario, even if the total weight of the truck changes its geometry remains equal. As a result, parameters affected by the geometry as the drag coefficient do not vary.

	MEET	Comprehensive
<b>A-15</b>	22.07	23.83
<b>N-121-A</b>	16.31	21.26

Table 21: Figure 51: Litres of diesel combusted in N-121-A and A-15 with empty semi-trailer

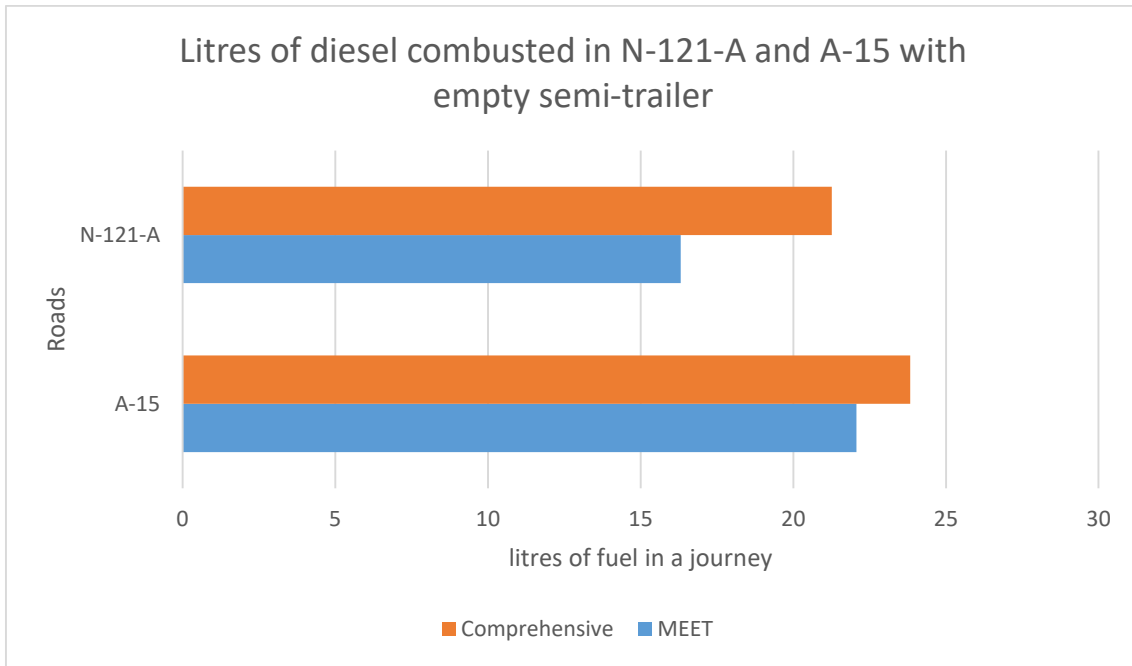

Figure 50: Litres of diesel combusted in N-121-A and A-15 with empty semi-trailer

### 5.4.3. Using a single tractor unit

If instead of the usual tractor plus semitrailer disposition a single tractor unit is studied, its mass will be of 9.73 tons. In the case of MEET method, as emission results vary in ranges of mass and in this case the range is between 7,5 and 16 tons the results will be the same that for the case of the empty semi-trailer case. Obviously these won't happen in reality and the single tractor's fuel consumption will be lower but these models give estimations and it is impossible to approximate them to reality at 100%.

The geometry of the truck changes, consequently the drag coefficient applied in the Comprehensive method too. However, the drag coefficient of a single tractor unit is the same of the drag coefficient of a tractor and semi-trailer structure and remains in 0.7.

	<b>MEET</b>	<b>Comprehensive</b>
<b>A-15</b>	22.07	21.55
<b>N-121-A</b>	16.31	19.73

Table 22: Litres of diesel combusted in N-121-A and A-15 with empty semi-trailer

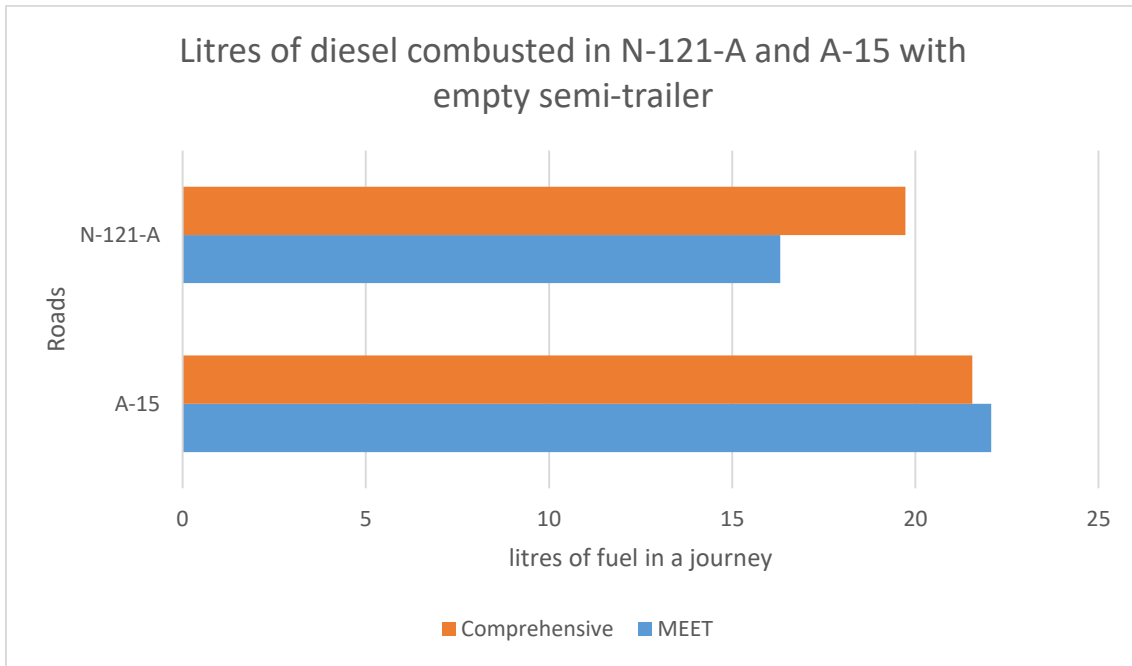
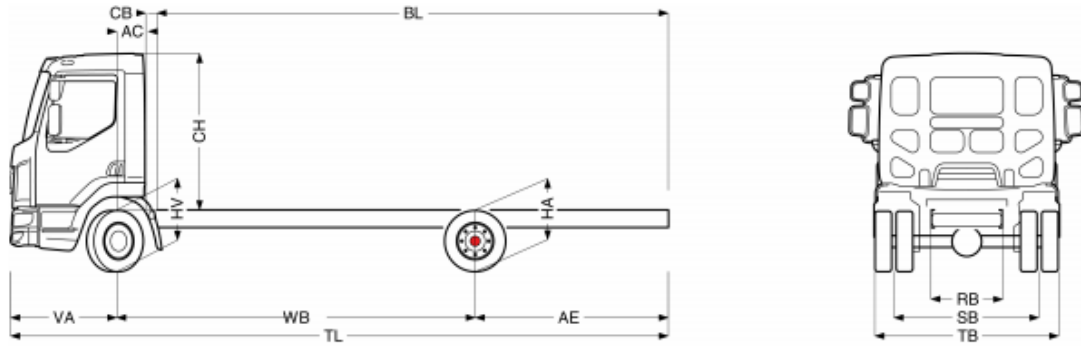

Figure 51: Litres of diesel combusted in N-121-A and A-15 with empty semi-trailer

#### 5.4.4. Change in the vehicle (using a smaller vehicle)

Until now the analysis was performed for a prototype semitrailer truck (tractor unit + semitrailer) of around 30 tons of weight. However, in the roads there are a great variety of heavy vehicles of every kind of weights depending on the load they transport. As a result, in order to make this study more applicable to any kind of truck, it has been decided to perform the same models and equations before in a smaller prototype truck.

In this context a compact truck has been chosen to perform this analysis. The model in question is the DAF LF 150 model of the same manufacturer used until now. It has a GVM of 7500kg and it is a compact truck.



	Wheelbase - AE		Unladen weight*			Gross Carrying Capacity			Variable dimensions							
	WB	AE <sup>1)</sup>	Front	Rear	Total	Front	Rear	Total	AC	CB <sup>2)</sup>	CH <sup>3)</sup>	BL <sup>4)</sup>	BL	TL	HA <sup>5)</sup>	HA <sup>10)</sup>
DAY CAB	3.05	1.80	2411	877	3288	1159	4123	4212	0.33	0.12	1.84	3.46	5.07	6.13	0.89	0.79
	3.15	1.82	2419	884	3283	1151	4136	4217	0.33	0.12	1.84	3.64	5.28	6.11	0.89	0.79
	3.55	1.87	2435	886	3321	1165	4114	4179	0.33	0.12	1.84	4.22	6.09	6.79	0.89	0.79
	3.90	2.12	2442	907	3339	1158	4103	4161	0.33	0.12	1.84	4.73	6.79	7.38	0.89	0.79
	4.30	2.32	2452	909	3360	1148	4091	4140	0.33	0.12	1.84	5.31	7.55	8.06	0.89	0.79
	4.65	2.65	2458	929	3387	1142	4071	4113	0.33	0.12	1.84	5.82	7.55	8.65	0.89	0.79
	5.00	2.72	2470	937	3407	1130	4063	4093	0.33	0.12	1.84	6.34	7.55	9.26	0.89	0.79

OTHER DIMENSIONS VA: 1.28 HV<sup>11)</sup>: 0.78 HV<sup>12)</sup>: 0.74 RB: 0.86 SB: 1.74 TB: 2.55



ENGINES
LF 150 PX-4 (115 kW / 156 hp)
LF 170 PX-4 (127 kW / 172 hp)

GVM <sup>1)</sup>	GCM <sup>2)</sup>
7500 kg	7500 kg
Max. front 3600 kg	
Max. rear 5000 kg	

Figure 52: DAF LF 150 model and its features

It has a Paccar PX-4 engine with a piston displacement of 3.8 litres and a compression ratio of 17.3 to 1. However, there was no data to find the gear ratios for every gear of this engine so the specified engine speed (2600 rpm) of the page of characteristics has been used when applying the Comprehensive study.

For applying the models some differences have been taken in account when applying different equations. For MEET model all the parameters applied in the equation have changed, as they depend in the load of the vehicles. The category of heavy vehicles



between 3.5 and 7.5 tons has been considered. With respect to Comprehensive model some parameters have changed: piston displacement, load, front area of the truck...

When applying both models (MEET and Comprehensive) the following results have been got in litres of fuel:

	<b>MEET</b>	<b>Comprehensive</b>
<b>A-15</b>	19.81	15.25
<b>N-121-A</b>	13.83	13.89

Table 23: Litres of diesel combusted in N-121-A and A-15

For the N-121-A, similar values have been achieved for both models, however for the A-15 there is quite a difference between both. In any case, both models show that for smaller compact trucks N-121-A is a better road in terms of fuel consumption and emissions related to it.

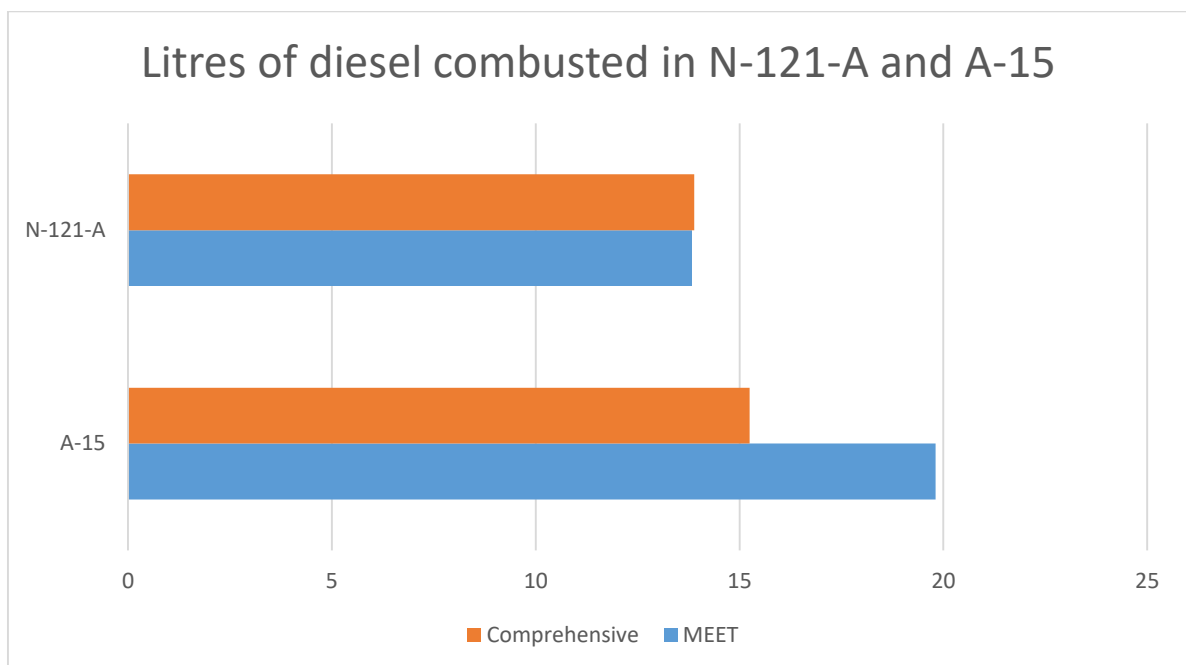

Figure 53: Litres of diesel combusted in N-121-A and A-15

Finally, these graphs contain fuel consumption results compared for both roads (N-121-A and A-15). Results are categorized by the emission calculation models studied (MEET and Comprehensive) and for the different truck dispositions (the original truck disposition considered in the assumptions and the different truck dispositions in the sensitivity analysis).

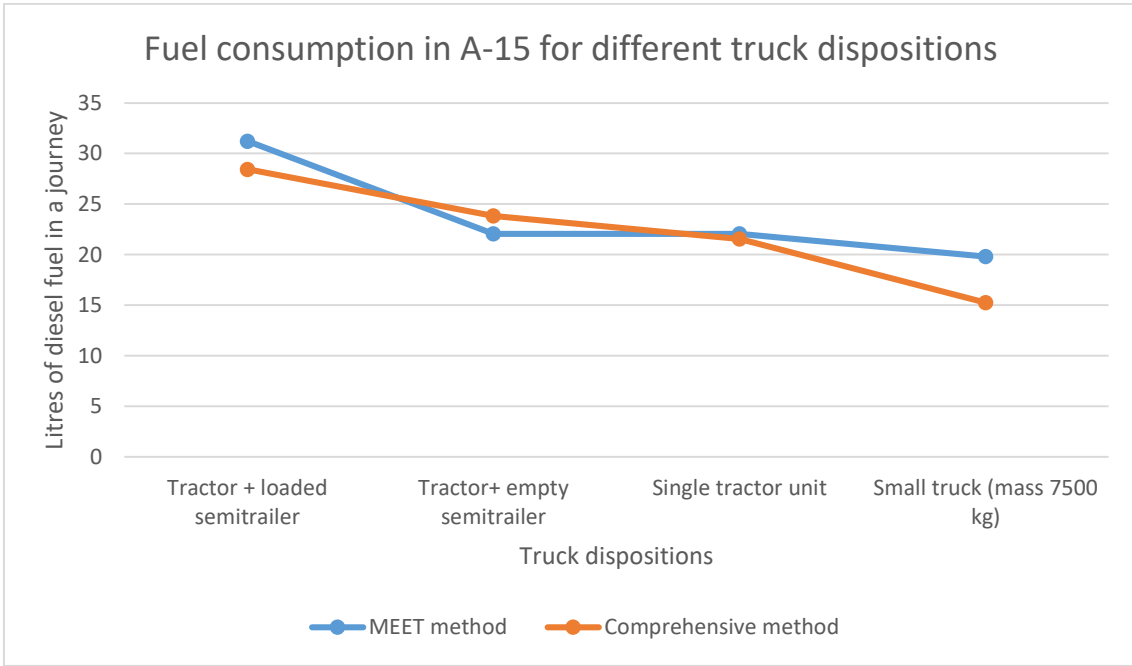

Figure 54: Fuel consumption in A-15 for different truck dispositions

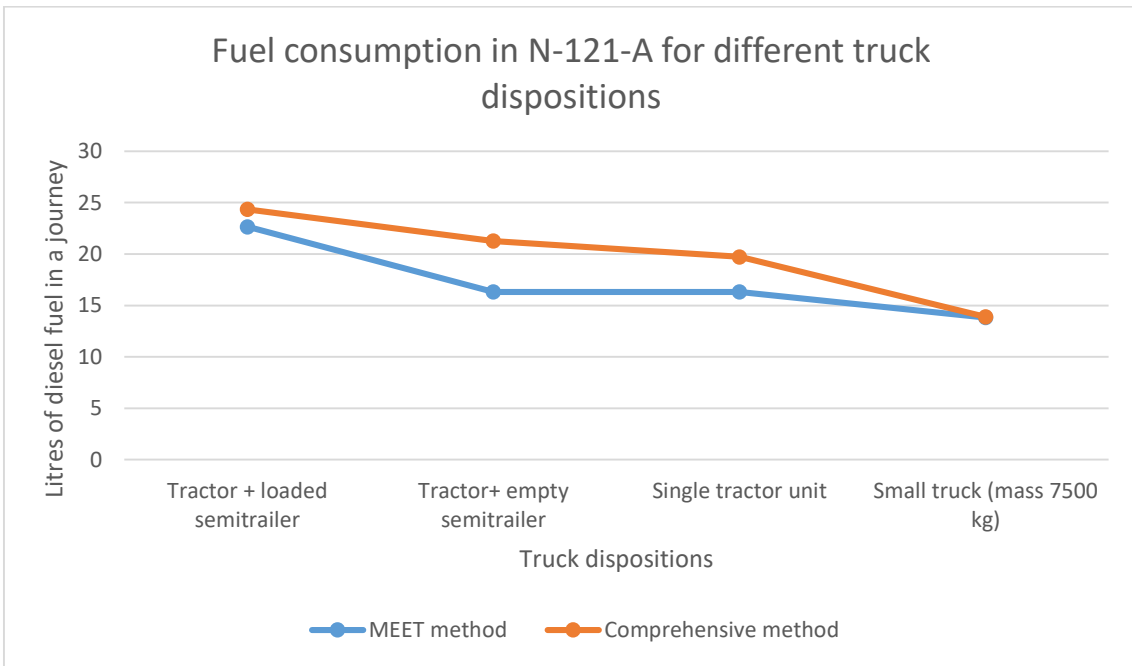

Figure 55: Fuel consumption in N-121-A for different truck dispositions

## 6. CONCLUSIONS

In this project two different models have been finally used for assessing the consumption of fuel of heavy freight transportation vehicles in N-121-A and A-15 roads, and its following roads in the case of N-121-A until the border with France in Irun. This models were explained and developed in the sections before, until some results have been obtained. However, all these previous investigations are useless if the numerical values of the results are not interpreted and put in context within the treated problem's scope. In this context, different conclusions have been reached regarding different aspects of the project studied:

Regarding the use of the models (Demir et al., 2011) the following conclusions have been reached:

- Comprehensive model seems a better model in order to perform sensitivity analysis of results. Usually, when performing sensitivity analysis different types of trucks or different dispositions are studied. As a result, what changes mainly between different scenarios is mainly the weight and the geometry of the vehicles. Comprehensive model allows changing both aspects, the mass of the vehicle is introduced in the equation in its exact value and the geometry can be taken in account with the drag coefficient. We can conclude that it is a model that regardless which is its similarity to real values that would be get if results would be got in an empirical way, it adapts very well to small modifications.
- However, in the case of the MEET model the geometry is not taken in account and the mass is taken in account but parameters change in intervals (for instance from 16 to 32 tons). So for different weights within this interval the value of fuel consumption will be the same even if reality a truck of 32 tons will have a much higher emission value compared to one of 16 tons.
- All this taken in account, results got with Comprehensive model seem more lineal according to the mass of the vehicle; whereas results got with MEET model are not lineal in any case and seem to represent a discontinuous function if the weight of the vehicle is in the abscissa axis and the emission fuel consumption in the ordinate.
- Even if there are differences in how both models adapt to modifications of certain parameters, both models are trustworthy for having an estimation of fuel consumption. In many cases, the results got for both MEET and Comprehensive models are very similar even if the assumptions that have to be made in order to estimate them are completely different and the parameters introduced too. The highest difference between models, higher than 4 litres of fuel, was in the case of N-121-A road when a smaller vehicle was considered (with a weight ranging between 3.5 and 7.5 tons). However, in this case there was no data of gear ratios that is necessary for implementing Comprehensive model so a specified constant engine rpm has been used instead of a rpm which varies depending on the speed.

So in this case the difference could be caused because a lack of data more than because uncertainty in the model itself.

Regarding the results got from the implementation of the models for both roads:

- From the environmental emission study, the main conclusion is that N-121-A is the best alternative with both methods used for assessing fuel consumption. N-121-A is a shorter alternative in distance and goes also through an orography that makes it more accurate for emission reduction. In all the different scenarios that have been built during the sensitivity analysis the fuel consumption is lower in the case of N-121-A.
- However, due to its two lane disposition and the high amount of trucks going through it, the accident rates are dangerously high in N-121-A. Converting the road in a 2+1 lane road could reduce this high accident rate without losing the advantages in fuel savings. The implementation of this type of lane would be also profitable from a financial point of view because it allows a reduction of cost due to the decrease in victims. This same conclusion is not new and has been stated in statistics and different previous studies, but it is important emphasising in it.

From the external and internal economic analysis of both alternatives the following conclusions are achieved:

- Internal costs, calculated with ACOTRAM tool, are smaller in the case of N-121-A than in the case of A-15. This happens because this tool elaborates an analysis taking in account vehicle parameters and then results are given in function of year costs or costs per kilometre. As N-121-A route is shorter in distance its internal cost value is also lower with this model.
- In the case of external costs, the value of N-121-A is lower than the value A-15 but with a very small difference. It is only lower due to its shorter distance, as for many external costs the value in motorways is higher than the value in conventional roads. However, assessing external costs involves a higher uncertainty as it is explained in the following points.
- As it was stated in the literature, with this study it can be verified that determining monetary values for internalizing externalities is a difficult task. Even if following the data of the same inform (by CE Delft for European Commission) the results can vary depending on the considerations made in order to reach them. For instance, this inform offers results for generic HGV vehicles, in vkm unit, without taking in account its load. At parallel, it offers also data which depends in the load that HGV-s transport, in this case in tkm units. Values in this last case result higher, because the considered vehicle for this study weighted 28 tons which between the highest categories within HGV-s.
- Average cost values of externalities are higher than marginal cost values in most cases. The only scenario where this is not the case is when roads start to be congested and their traffic flow situation changes from free flow conditions to full capacity. If capacity of roads is full the marginal cost of an additional vehicle in the road is very high (higher than 100€ per vehicle in some cases) whereas the

average cost of the vehicles that already were in the road is low. This might happen because when a road becomes collapsed the economic impact is very high in terms of delays and higher fuel consumption and the additional vehicles that enter to the roads are the ones which boost this situation affecting the whole traffic.

As future lines that can be analysed in following projects the upcoming ideas could be considered:

- Implementation of more models included in Demir et al. article or using COPERT in order to verify if the results are coherent with the models studied until the date.
- A deeper assessment of external costs that both roads have and solutions for its internalization could be done, as the external cost study was not the main focus of this project. It is known that there are several methods in order to externalize internal costs (i.e. Pigouvian taxes, government regulation etc.), knowing which of them is the more suitable to implement in this specific case could be very helpful both in economic and environmental aspects.

# 7. BIBLIOGRAPHY

## Written Bibliography:

- [1] American Association of State Highway and Transportation Officials. (2001). A policy on geometric design of highways and streets, 2001. Washington, D.C: American Association of State Highway and Transportation Officials.
- [2] Autopistas de Navarra. Peajes en Vigor a Partir del 1 de Enero de 2020. (2020)
- [3] Barth, M., An, F., Younglove, T., Scora, G., Levine, C., Ross, M., Wenzel, T., 2000. Comprehensive Modal Emission Model (CMEM), Version 2.0 Users Guide. Technical Report.
- [4] Barth, M., Boriboonsomsin, K., 2008. Real-world CO2 impacts of traffic congestion. *Transportation Research Record* 2058, 63–71.
- [5] Bergh T. , Remgård M. , Carlsson A., Olstam J. & Strömgren P.(2016) 2+1-roads Recent Swedish Capacity and Level-of-Service Experience. *Transportation Research Procedia* . Volume 15, 331–345
- [6] DAF, 2020. *Specification Sheet XF 430*.
- [7] DAF, 2020. *MX13 Engines of Paccar*.
- [8] Demir E., Bektas T. & Laporte G. (2011). A comparative analysis of several vehicle emission models for road freight transportation. *Transportation Research*, Part D 16, 347-357.
- [9] Demir E.,Huang Y., Scholts S. & Van Woensel T. (2015). A selected review on the negative externalities of the freight transportation: Modeling and pricing. *Transportation Research D*, Part E 77, 95-114.
- [10] Dirección General de Carreteras. (2016, March). *Trazado: Instrucción de Carreteras Norma 3.1-IC*. Ministerio de Fomento, Gobierno de España.
- [11] Dirección General de Tráfico. Observatorio Nacional de Seguridad Vial. Las Principales Cifras de la Sinestralidad Vial. (2018)
- [12] Departamento de Obras Públicas, Transportes y Telecomunicaciones, Gobierno de Navarra. (2011). *III Plan Director de Carreteras de Navarra*. Pamplona.
- [13] Hurtado T. & Bruno G. El Proceso de Análisis Jerárquico (AHP) como Herramienta para la Toma de Decisiones en la Selección de Proveedores.
- [14] Faulin J.,Grisman E., Juan A.A. & Hirsch P. (2019). *Sustainable Transportation and Smart Logistics*. Amsterdam, Netherlands: Elsevier.
- [15] Hickman, J., Hassel, D., Joumard, R., Samaras, Z., Sorenson, S., 1999. *MEET-Methodology for Calculating Transport Emissions and Energy Consumption*. European Commission, DG VII. Technical Report.
- [16] Kent, J.H., Post, K., Tomlin, J.A. (1982). Fuel consumption and emission modelling in traffic links. In: *Proceedings of SAE-A/ARRB 2nd Conference on Traffic Energy and Emissions*, Melbourne.
- [17] Kovács G. (2017). First Cost Calculation Methods for Road Freight Transportation Activity. *Transport and Telecommunication*, 18 no.2, 107-117. 15/04/2020, Fom ResearchGate database

- [18] Ministère de L'Aménagement du Territoire, de L'Équipement, du Logement et du Tourisme. (1972, december). *Guide de Bruit: Des Routes Urbaines et des Implications Techniques*. Imprimerie, La Familiale.
- [19] Ministerio de Fomento, Gobierno de España & Ministère de la Transition Écologique et Solidaire, République Française. (2018). *Observatorio Hispano-Francés de Tráfico en los Pirineos. Documento nº 8*. Madrid, Toulouse.
- [20] Ministerio de Fomento, Gobierno de España & Ministère de la Transition Écologique et Solidaire, République Française. (2019). *Observatorio Hispano-Francés de Tráfico en los Pirineos. Suplemento al Documento nº 8. Principales Cifras Actualizadas para los Años 2015 y 2016*. Madrid, Toulouse.
- [21] Ministerio de Transportes, Movilidad y Agenda Urbana, Gobierno de España. (2020). *Observatorio de Costes del Transporte de Mercancías por Carretera*. Madrid.
- [22] Nowakowska-Grunt, J., & Strzelczyk, M. (2019). *The current situation and the directions of changes in road freight transport in the European Union*. *Transportation Research Procedia*, 39, 350-359.  
<https://doi.org/10.1016/j.trpro.2019.06.037>
- [23] Ranaiefar, F., & Amelia, R. (2011). Freight-Transportation Externalities. *Logistics Operations and Management*, 333-358.  
<https://doi.org/10.1016/b978-0-12-385202-1.00016-5>
- [24] Saaty T. M. *The Analytical Hierarchical Process*, J. Wiley, New York, 1980.
- [25] Segués Echezarreta, F. (2007–2008). *Ruido de Tráfico: Carreteras*. EOI Escuela de Negocios.
- [26] Sedano A. L. *ESTT - OEP 2014 Parte 1: Movilidad Segura. Tema 11, Consecuencias del Accidente: Consecuencias Económicas y Sociales* (2014)
- [27] Zúñiga B. *ESTT - OEP 2014 Parte 1: Movilidad Segura. Tema 5, Las Consecuencias del Accidente: Consecuencias Individuales y Sociales* (2014)

## Web Bibliography:

- [1] 20 years of truck fuel efficiency – what progress? methodological note. In Transport and Environment. Last access July 2020 from [https://www.transportenvironment.org/sites/te/files/2016\\_09\\_Blog\\_20\\_years\\_no\\_progress\\_methodological\\_note\\_final.pdf](https://www.transportenvironment.org/sites/te/files/2016_09_Blog_20_years_no_progress_methodological_note_final.pdf)
- [2] Álvarez A. (2019). *El nuevo Reglamento de Ordenación del Transporte Terrestre*. Sertrans. Last access October 2020 in <https://www.sertrans.es/transporte-terrestre/el-nuevo-reglamento-de-ordenacion-del-transporte-terrestre/>
- [3] Analytic Hierarchy Process. In Wikipedia. Last access August 2020 in [https://en.wikipedia.org/wiki/Analytic\\_hierarchy\\_process](https://en.wikipedia.org/wiki/Analytic_hierarchy_process)
- [4] Autovía/Autopista del Cantábrico. In Wikipedia. Last access May 2020 in [https://es.wikipedia.org/wiki/Autov%C3%ADa/Autopista\\_del\\_Cant%C3%A1brico](https://es.wikipedia.org/wiki/Autov%C3%ADa/Autopista_del_Cant%C3%A1brico)
- [5] Autovía de Navarra. In Wikipedia. Last access April 2020 in [https://es.wikipedia.org/wiki/Autov%C3%ADa\\_de\\_Navarra](https://es.wikipedia.org/wiki/Autov%C3%ADa_de_Navarra)
- [6] Autovía del Norte. In Wikipedia. Last access May 2020 in [https://es.wikipedia.org/wiki/Autov%C3%ADa\\_del\\_Norte](https://es.wikipedia.org/wiki/Autov%C3%ADa_del_Norte)
- [7] Cobasés L. & Mitxitorena I. (2020, January 13). Las dos últimas víctimas elevan a 31 los fallecidos por tráfico en la N-121-A desde 2010. *Noticias de Navarra*. Last access April 2020 in <https://www.noticiasdenavarra.com/actualidad/sociedad/2020/01/13/n121a-accidentes-mortales-trafico-navarra/1014893.html>
- [8] DiariodeTransporte.com (2018, 15 november). *Análisis de la situación actual del transporte por carretera y los retos del sector para 2019*. Diario de Transporte. Last access August 2020 in <https://diariodetransporte.com/2018/11/analisis-de-la-situacion-actual-del-transporte-por-carretera-y-los-retos-del-sector-para-2019/>
- [9] Paccar MX-13 Engine. In Roadranger. Last access October 2020 in <http://www.roadranger.com/rr/ProductsServices/ProductsbyCategory/Integrated-Powertrains/MX-13/index.htm>
- [10] El Gobierno autoriza la contratación de los proyectos constructivos para acometer una mejora general de la carretera N-121-A. In Navarra.es. Last access July 2020 in [https://www.navarra.es/home\\_es/Actualidad/Sala+de+prensa/Noticias/2017/04/05/contratacion+proyectos+mejora+N-121-A.htm](https://www.navarra.es/home_es/Actualidad/Sala+de+prensa/Noticias/2017/04/05/contratacion+proyectos+mejora+N-121-A.htm)
- [11] EP Pamplona. (2020, February 20). La N-121-A, con 125 accidentes de media al año, tiene la mayor siniestralidad. *Noticias de Navarra*. Last access April 2020 in <https://www.noticiasdenavarra.com/actualidad/sociedad/2020/02/04/navarra-policia-foral-realizo-1452/1020520.html>
- [12] Explanatory note: Comparing US and EU truck fuel economy. In Transport and Environment (June 2015). Last access May 2020 in



- [https://www.transportenvironment.org/sites/te/files/2015\\_06\\_Comparing\\_US\\_EU\\_truck\\_fuel\\_economy\\_explanatory\\_note\\_Final.pdf](https://www.transportenvironment.org/sites/te/files/2015_06_Comparing_US_EU_truck_fuel_economy_explanatory_note_Final.pdf)
- [13] Geoportal de Navarra. In Sitna. Last access October 2020 in [https://sitna.navarra.es/geoportal/geop\\_sitna/geoportal.aspx](https://sitna.navarra.es/geoportal/geop_sitna/geoportal.aspx)
- [14] Global Road Freight Transportation Services Market 2020 by Company, Type and Application, Forecast to 2025 - Marketsandresearch.biz. (2020). Markets and Research. Last access August 2020 in <https://www.marketsandresearch.biz/report/71671/global-road-freight-transportation-services-market-2020-by-company-type-and-application-forecast-to-2025>
- [15] Hayes, H. Internal Rate of Return. In Investopedia. Last access August 2020 in <https://www.investopedia.com/terms/i/irr.asp>
- [16] How to calculate the CO2 emission in the fuel consumption? In Ecoscore. Last access May 2020 in <https://ecoscore.be/en/info/ecoscore/co2>
- [17] Internal Rate of Return. In Wikipedia. Last access September 2020 in [https://en.wikipedia.org/wiki/Internal\\_rate\\_of\\_return](https://en.wikipedia.org/wiki/Internal_rate_of_return)
- [18] Índice de variación mensual de los precios medios del gasóleo en España | Ministerio de Transportes, Movilidad y Agenda Urbana. (2020). Ministerio de Transportes, Movilidad y Agenda Urbana. Gobierno de España. Last access September 2020 in <https://www.mitma.gob.es/transporte-terrestre/servicios-al-transportista/indice-de-variacionmensual-de-los-precios-medios-del-gasoleo-en-espana>
- [19] Logistics, A. (2019). El transporte por carretera y los tipos de vehículos que encontramos. Algevasa LOGISTICS. Last access August 2020 in <https://www.algevasa.com/transporte-por-carretera-y-tipos-de-vehiculos/>
- [20] Los camiones diésel en Europa suponen el 98% de los vehículos pesados registrados en 2019. In PonleFreno. Last access June 2020 in [https://compromiso.atresmedia.com/ponlefreno/noticias/camiones-diesel-europa-suponen-vehiculos-pesados-registrados-2019\\_202004155e96d7ca7ea8b8000180eecd.html](https://compromiso.atresmedia.com/ponlefreno/noticias/camiones-diesel-europa-suponen-vehiculos-pesados-registrados-2019_202004155e96d7ca7ea8b8000180eecd.html)
- [21] N-121-A. In Wikipedia. Last access October 2020 in <https://es.wikipedia.org/wiki/N-121-A>
- [22] Navarra.com (2020, April 15). Comienzan las obras sobre la N-121-A para establecer la doble línea continua en toda la carretera. *El Español Navarra*. Last access April 2020 in <https://navarra.elespanol.com/articulo/sociedad/n-121-doble-linea-continua-obra-navarra-gobierno/20200415141827319456.html>
- [23] Precio de la gasolina y gasóleo (diesel) en España, cifras, datos y estadísticas. (2020, 19 march). Epdata. Last access August 2020 in <https://www.epdata.es/datos/precio-gasolina-gasoleo-diesel-espana-cifras-datos-estadisticas/420>
- [24] Puntos kilométricos de España. In ArcGIS. Last access October2020 in <https://www.arcgis.com/home/item.html?id=d8854f26fd5c4baab08337ca0f3aff6f>

- [25] Road to Zero: the last EU emission standard for cars, vans, buses and trucks. In Transport and Environment (April 2020). Last access May 2020 in [https://www.transportenvironment.org/sites/te/files/publications/2020\\_04\\_Road\\_to\\_Zero\\_last\\_EU\\_emission\\_standard\\_cars\\_vans\\_buses\\_trucks.pdf](https://www.transportenvironment.org/sites/te/files/publications/2020_04_Road_to_Zero_last_EU_emission_standard_cars_vans_buses_trucks.pdf)
- [26] Transporte de Mercancías por Carretera. In Transeop. Last access October 2020 in <https://www.transeop.com/blog/transporte-de-mercancias-por-carretera/299/>
- [27] Trends in road freight transport (2020) Last access August 2020 in <https://summit.movinonconnect.com/en/mobility/trends-in-road-freight-transport/#/>
- [28] What does Road Freight mean? Logistics Terms. (2020). Saloodo! Last access September 2020 in <https://www.saloodo.com/logistics-dictionary/road-freight/>
- [29] What is Geographic Information Systems (GIS)? In GisGeography. Last access October 2020 in <https://gisgeography.com/what-gis-geographic-information-systems/>

## 8. ANNEX

Other externalities that can be taken in account when assessing the impact of infrastructures are the damage to inhabitants of surrounding areas because of noise pollution (1.2.6.3) and damage to local environment related to land use (1.2.6.7). However, as calculating these effects was not the main aim of this study and they were done in with less deep insight they are included in the annex.

### 8.1. Acoustic study

For calculation of the acoustic impact of both roads Guide de Bruit's (France) method is used. This method is a single method, so it cannot be considered as a precision method. It is valid for the use in environmental impact studies as an informative study or draft. For more detailed studies, it has to be enlarged with other methods and correction tables, or a method supported by a computer tool has to be used.

Its use is restricted to the following cases:

- Motorways, highways and national roads.
- Two-lane expressways (motorways, peripheral roads...) in surroundings of cities (with houses or buildings with big separation between them) with an average speed higher than 60 km/h.
- Avenues or boulevards with high traffic density and a circulation speed higher than 60 km/h.

The method is based in the calculation of  $L_{Aeq}$  of a receiver located 2 metres away from a facade of a building. The formula for a  $L_{Aeq}$  of 1 hour is:

$$L_{Aeq} = S + 10 * \log(Qvl + E * Qpl) + 20 * \log V - 12 * \log\left(d + \frac{lc}{3}\right) + 10 * \log\left(\frac{\theta}{180}\right) - K_{reflex} - K \quad (1)$$

Where:

S: Constant related to the emission of a light vehicle. The method shows that its value is 20, but with the reduction in emission of vehicles now it is better to adopt a value of 18.

Qvl, Qpl: Number of light and heavy vehicles in an hour

E: Equivalence factor between heavy and light vehicles (depends in type of road and the grade)

V: Speed in km/h

d: Distance to the edge of the road, in metres

lc: Width of the road in metres

$\theta$ : Grade of the road in deg

$K_{reflex}$ : Correction in the case the receiver is not located in the facade of a building ( $K_{reflex}=3$ )

K: Corrections for different effects (i.e. embankments, obstacles, ground effect etc.)

This formula gives the resonant level just for an hour. For evaluating the  $L_{Aeq}$  of a specific period it is precise to define the traffic in a representative hour of T period.

### 8.1.1. Representative vehicles

There are two categories of vehicles:

- Light vehicles: Its total weight charged is lower or equal to 3.5 T
- Heavy vehicles: Its total weight charged is higher or equal to 3.5 T

Referring to the number of vehicles in the representative hour, the method recommends the use of the following values in function of average daily traffic (ADT).

$$Q_{\text{representative hour of daily period}} = ADT / C_{\text{day}} \quad (2)$$

Where  $C_{\text{day}}$  changes between 16 and 19 depending the type of road and traffic

$$Q_{\text{representative hour of night period}} = ADT / C_{\text{day}} \quad (3)$$

Where  $C_{\text{night}}$  changes between 90 and 160 depending the type of road and traffic

### 8.1.2. Accoustic equivalence E and grade correction

In the following table, E equivalence factor's values are given in function of numerous measures of type of road and percentage of slope:

	r<<2%	r=3%	r=4%	r=5%	r>6%
<b>Motorway (110-120 km/h)</b>	E=4	5	5	6	6
<b>Conventional road (90-100 km/h)</b>	7	7	10	11	12
<b>Boulevard type road (60-80 km/h)</b>	10	13	16	18	20

Annex table 1: Equivalence factor between heavy and light vehicles in Guide de Bruit's

### 8.1.3. Speed

The speed considered corresponds to that reached by the majority of vehicles in the traffic flow (speed reached or surpassed by 50% of vehicles during observation period).

In two-lane speedways the following speeds can be considered:

- Motorway: v=120 km/h
- Highway: v=100-120 km/h
- Conventional road: v=80-90 km/h
- Boulevard type road: v=60-80 km/h

#### **8.1.4. Application of the method to N-121-A and A-15 (AP-15)**

In order to apply the method to this specific case the following considerations were taken:

- In order to establish the traffic flow of both roads "*Mapa de Intensidades Medias Diarias Todos los Vehículos Año 2019*" elaborated by Government of Navarre has been used. This map is very accurate because it gives information of the average number of heavy and light vehicles per day in different segments of AP-15, A-15 and N-121-A. As there is not data for every town in the road, the closest informative point has been considered for every town.
- In order to determine the distance between different towns to roads, SITNA GIS application has been used with its tool to measure the distance between two points of the map. Central points of towns have been selected as the points to measure from in towns, in consequence there will be points in town which are closer to the roads and experience a higher accoustic impact and the opposite case.
- In order to determine the speed of the roads the previous study carried out for the fuel consumption has been used. However, in the case of A-15, as in this case for cars the standard speed is of 120 km/h, this last value has been considered in most of the towns. In the case of grades of roads this same previous study has been considered (choosing the grade that was determined for doing the emission study for which the elevation profiles have been elaborated for the hole routes).
- For establishing the width of the roads, 3.1 IC Normative by "*Ministerio de Transportes, Movilidad y Agenda Urbana*" has been used, which includes information about the standard parameters of road dimensioning.
- For calculation of heavy vehicles correction coefficient E, the corrective table has been used which gives its value.

### 8.1.5. Results

With all this taken in account,  $L_{aeq}$  has been calculated for all the towns in Navarre of both routes and also the multiplication of  $L_{aeq}$  \*population.

<b>N-121-A</b>			
<b>Town</b>	<b><math>L_{aeq}</math></b>	<b>Population</b>	<b>Population*<math>L_{aeq}</math></b>
Oricain	31.14	120	3736.8
Sorauren	25.71	193	4962.03
Olave	30.38	73	2217.74
Enderiz	31.69	102	3232.38
Ostiz	37.91	89	3373.99
Burutuain	30.44	82	2496.08
Etulain	30.59	37	1131.83
Olague	36.92	223	8233.16
Ventas de Arraitz	46.29	199	9211.71
Almandoz	40.43	205	8288.15
Berroeta	38.34	123	4715.82
Zozaia	36.95	34	1256.3
Oronoz	22.93	428	9814.04
Oieregi	33.17	52	1724.84
Narbarte	29.74	284	8446.16
Legasa	30.74	254	7807.96
Doneztebe/Sanesteban	26.59	1726	45894.34
Sunbilla	25.9	675	17482.5
Berrizaun	26.39	62	1636.18
Bera	27.86	3736	104084.96
<b>Total</b>			<b>249746.97</b>

*Annex table 2:  $L_{aeq}$  calculation for towns in N-121-A*





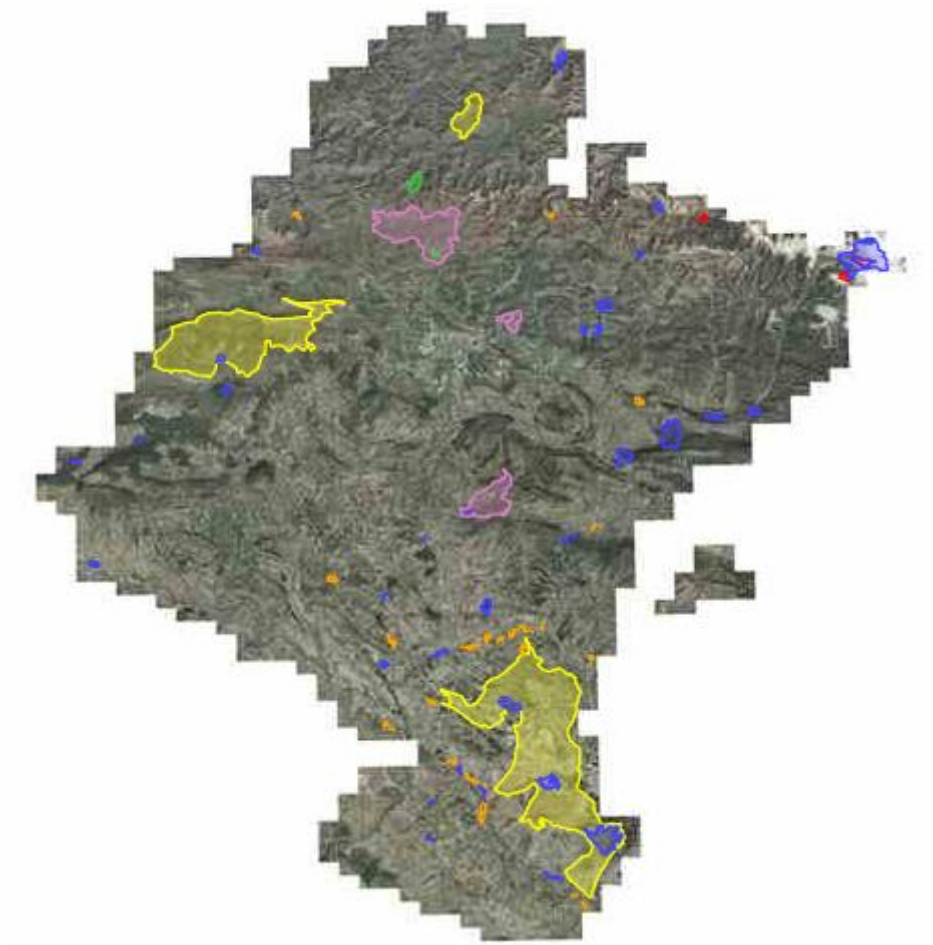

<b>A-15</b>			
<b>Town</b>	<b>L_aeq</b>	<b>Population</b>	<b>Population*L_aeq</b>
Berrioplano	26.89	651	17505.39
Larragueta	37.03	88	3258.64
Zuasti	30.12	411	12379.32
Aldaba	27.85	69	1921.65
Sarasa	21.46	132	2832.72
Aldaz	18.23	130	2369.9
Erice de Iza	29.43	53	1559.79
Sarasate	22.56	32	721.92
Izurdiaga	25.55	168	4292.4
Irurtzun	22.12	2183	48287.96
Goldaratz	17.54	35	613.9
Latasa	25.43	83	2110.69
Urritza	33.74	40	1349.6
Arruitz	25.5	102	2601
Lekunberri	27.43	1502	41199.86
Gorriti	34.02	87	2959.74
Areso	38.29	279	10682.91
<b>Total</b>			<b>156647.39</b>

*Annex table 3: L\_aeq calculation for towns in A-15*

## **8.2. Study of biodiversity and protected areas**

In order to study the environmental accuracy of the roads, other parameters will be taken in account. For instance, the noise pollution caused by the roads in the populations crossed and how these roads affect biodiversity by the effect they have in the protected areas close to them.



-  Recreational nature areas
-  Nature parks
-  Fully protected nature reserves
-  Nature enclaves
-  Nature reserves
-  Protected landscapes

*Annex figure 1: Protected areas in Navarre (Source: Government of Navarre)*

In order to see which road is more friendly from an environmental point of view, regarding the protected areas close to them, SITNA GIS tool by government of Navarre has been used. SITNA offers a layer that gives information in the map about the different protected areas in the Foral community and its protection category. The protected areas in the community of Navarre include 3 nature parks, 3 fully protected nature reserves, 38 nature reserves, 28 nature enclaves, 2 recreational nature areas, 17 special protection areas for fowl (called ZEPA, *Zonas de Especial Protección para las Aves*) and 14 special protection areas for wild fauna.



However, not all these protected areas are close to the roads studied. In order to compute those which are close to N-121-A and A-15 (or AP-15), a radio of 5km has been established and protected areas have been counted in this radio for both roads.

From this point of view, A-15 seems a better alternative as it just passes close (5km or less) to 3 environmentally protected areas, whereas N-121-A passes close to 4 of them and crosses a fifth one.

### 8.2.1. Protected areas close to N-121-A and A-15

Protected area	Protection Category	Road	Crossing road or at distance	Distance
Egubalti	Protected landscape	N-121-A	At distance	5.115 km
Orgi Forest	Recreational natural area	N-121-A	At distance	4.145 km
Robledales de Ultzama y Basaburua	Protected landscape	N-121-A	Crossing road (during 3,1 km)	/
Señorío de Bertiz	Natural park	N-121-A	At distance	0.18 km
San Juan Xar	Natural reserve	N-121-A	At distance	2.78 km
Urbasa Andia	Natural park	A-15	At distance	3.9 km
Robledales de Ultzama y Basaburua	Protected landscape	A-15	At distance	3.77 km
Encinares de Zigadia Betelu	Natural enclave	A-15	At distance	1.83 km

Annex table 4: Protected areas close to N-121-A and A-15

### 8.2.2. Protected areas close to N-121-A

Egubalti protected landscape:

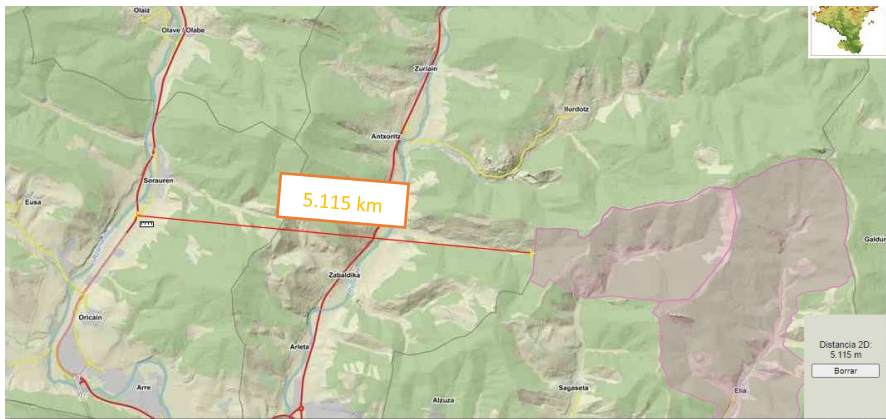

Annex figure 2: Distance of a protected area measured with SITNA tool

Orgi Forest recreational natural area:

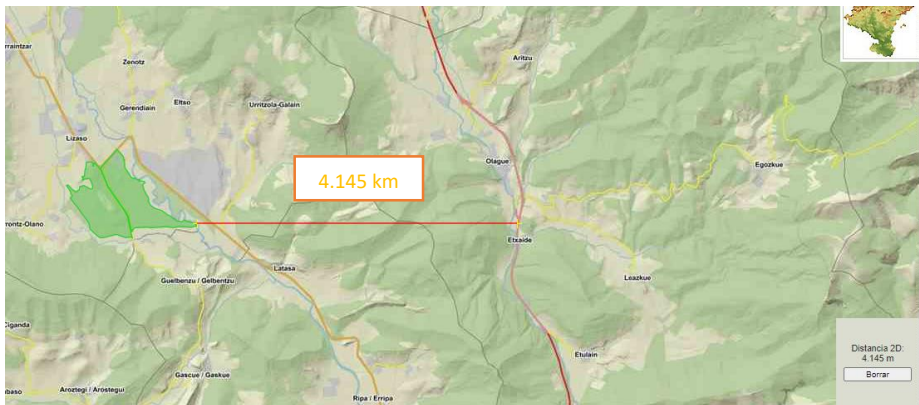

Annex figure 3: Distance of a protected area measured with SITNA tool

Robledales de Ultzama y Basaburua/ Ultzama eta Basaburuko Hariztiak protected landscape:

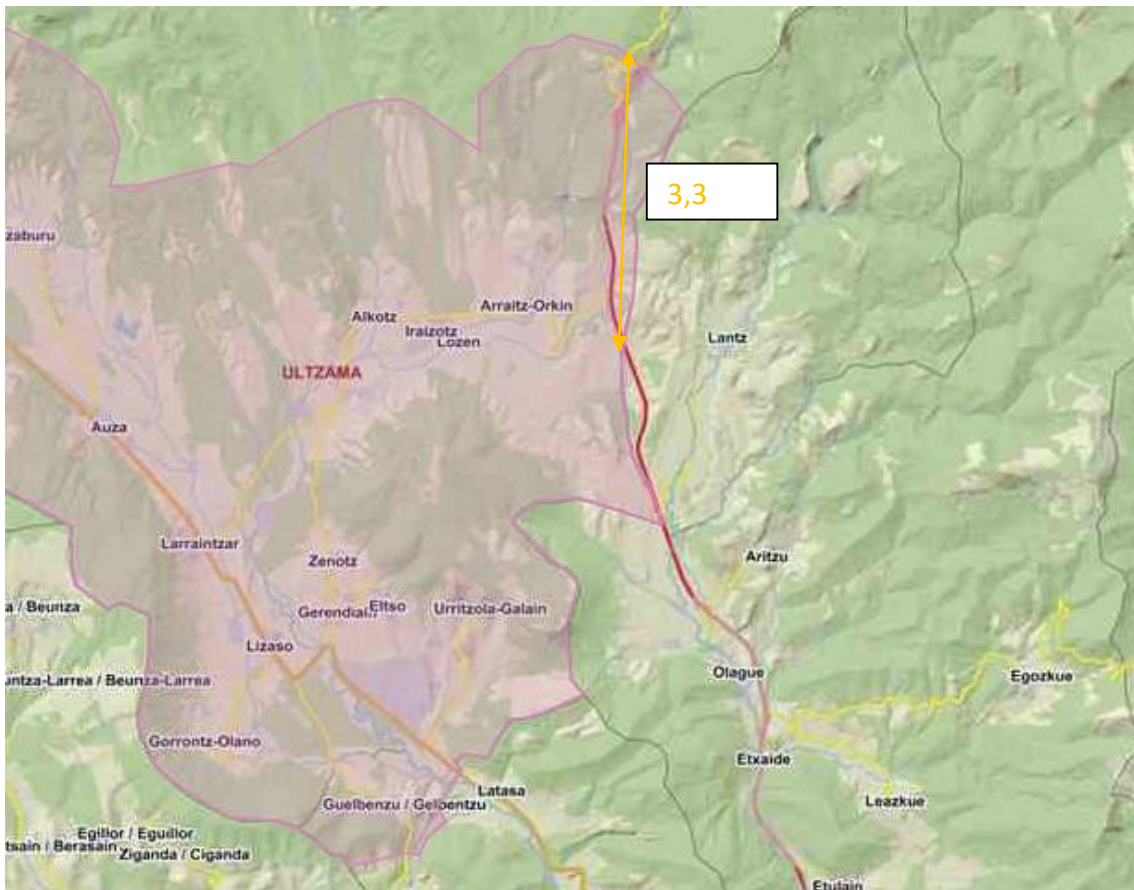

Annex figure 4: Distance of a protected area measured with SITNA tool

Señorío de Bertiz natural park:

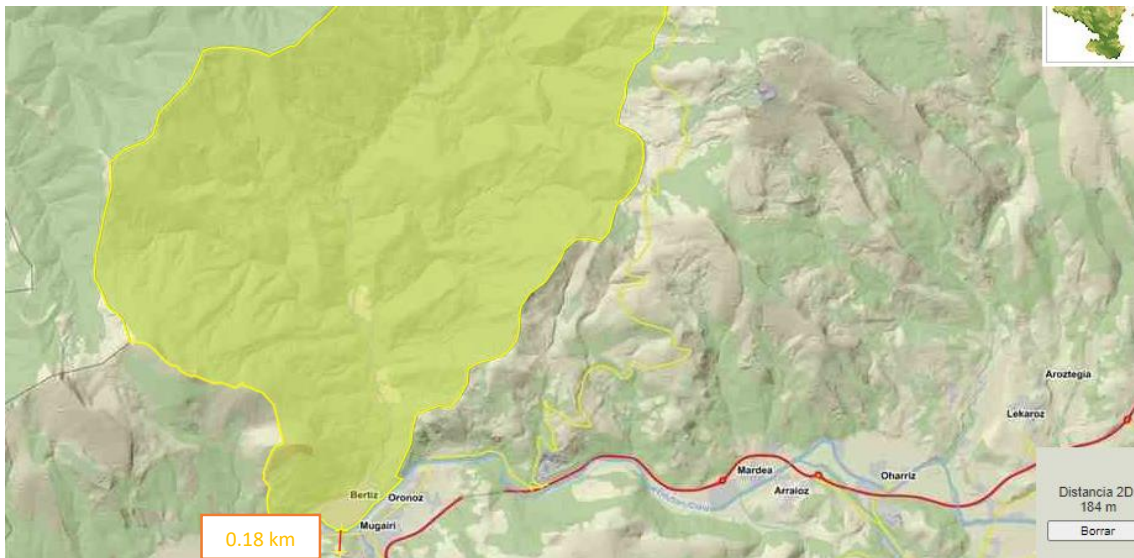

Annex figure 5: Distance of a protected area measured with SITNA tool

San Juan Xar natural reserve:

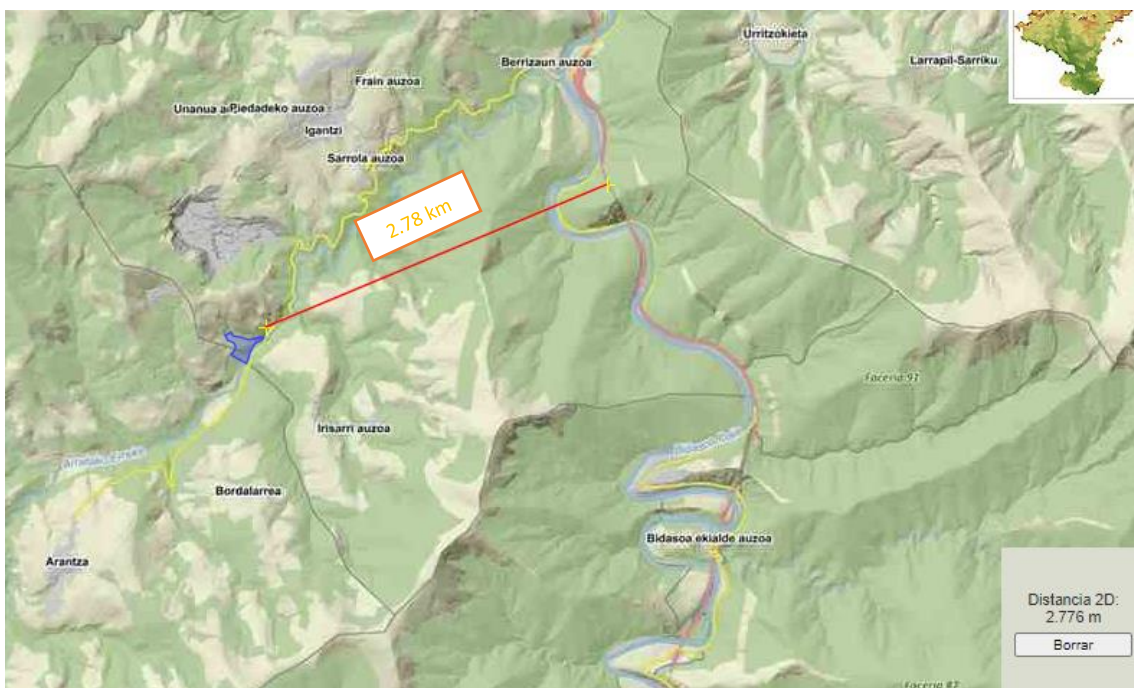

Annex figure 6: Distance of a protected area measured with SITNA tool

**8.2.3. Protected areas close to A-15:**  
Urbasa Andia natural park



Annex figure 7: Distance of a protected area measured with SITNA tool

**Robledales de Ultzama y Basaburua/ Ultzama eta Basaburuko Hariztiak protected landscape:**

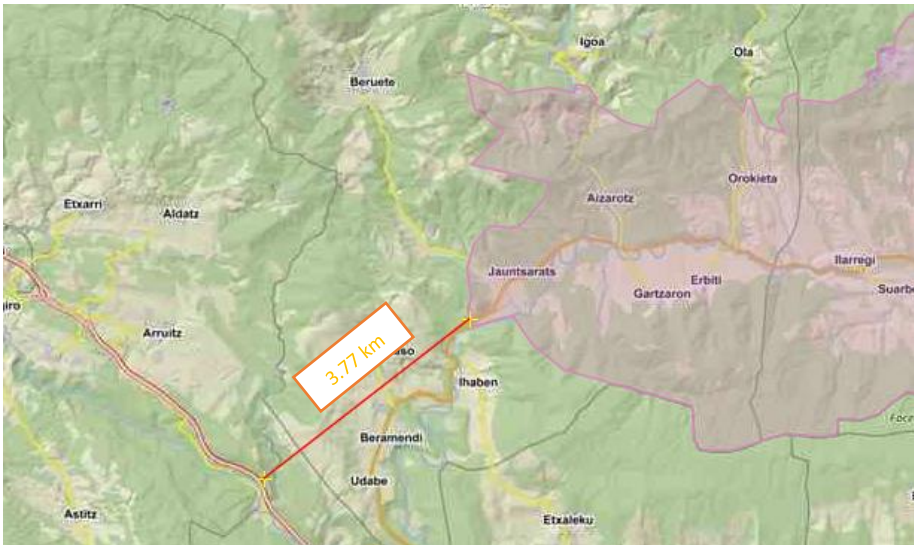

Annex figure 8: Distance of a protected area measured with SITNA tool

Encinares de Zigadia Betelu nature enclaves:



*Annex figure 9: Distance of a protected area measured with SITNA tool*